

HN6841FR

Induction Hob

Installation, Use and Maintenance



Important

The CDA Group Ltd cannot be held responsible for injuries or losses caused by incorrect use or installation of this product. Please note that CDA reserve the right to invalidate the guarantee supplied with this product following incorrect installation or misuse of the appliance or use in a commercial environment.

This appliance is not designed to be used by people (including children) with reduced physical, sensorial or mental capacity, or who lack experience or knowledge about it, unless they have had supervision or instructions on how to use the appliance by someone who is responsible for their safety.

Under no circumstances should any external covers be removed for servicing or maintenance except by suitably qualified personnel.

Appliance information:

Please enter the details on the appliance rating plate below for reference, to assist CDA Customer Care in the event of a fault with your appliance and to register your appliance for guarantee purposes.

Appliance Model	
Serial Number	

EU Declarations of Conformity

This appliance has been manufactured to the strictest standards and complies with all applicable legislation, including Electrical safety (LVD) 2014/35/EU and Electromagnetic interference compatibility

(EMC) 2014/30/EU. Parts intended to come into contact with food conform to 1935/2004/EC.

IMPORTANT INFORMATION FOR CORRECT DISPOSAL OF THE PRODUCT IN ACCORDANCE WITH EC DIRECTIVE 2012/19/EU.

At the end of its working life, the product must be taken to a special local authority waste collection centre or to a dealer providing appliance recycling services.

Disposing of a household appliance separately avoids possible negative consequences for the environment and health. It also enables the constituent materials to be recovered, saving both energy and resources. As a reminder of the need to dispose of household appliances separately, the product is marked with a crossed-out wheeled dustbin. 

Please note:

- Induction hobs become hot and remain hot during and immediately after use. Do not touch the hob until it has been allowed to cool.
- Keep children away from the appliance when in use.
- Never use the hob top for storage.
- Pan handles should never stand out beyond the edge of the worktop. This will help to avoid children reaching them.
- Do not lean over the hob when it is in use.
- Follow the cleaning instructions carefully.
- Ensure the base of the saucepan is clean and dry before placing it on the hob.
- Avoid hard shocks from cookware – the vitroc ceramic glass surface is highly resistant but not unbreakable.

- Do not place hot lids flat on the hob top. A “suction” effect could cause damage to the hob.
- Do not drag cookware across the hob top: in the long term, this could cause damage to the hob.
- Do not store cleaning or flammable products in the unit below the hob.
- Always use appropriate cookware.
- Do not cook unopened tins of food directly on the hob.
- Never put cooking foil or plastic materials on the ceramic surface when the hob is hot. These materials could melt and cause damage to the hob.
- This hob (Class 3) has been designed for use only as a cooking appliance. Any other use should be considered incorrect and therefore dangerous.

FOR THOSE WITH HEART PACEMAKERS OR ACTIVE IMPLANTS:

The function of this hob conforms to current electromagnetic interference standards and thus is in total compliance with legal requirements (2004/108/CE directives).

To avoid interference between your hob and a pacemaker, your pacemaker must be designed and programmed in compliance with the regulations that apply to it. As such, CDA guarantee only that our product is compliant.

With regard to the compliance of the pacemaker or any potential incompatibility, you should obtain information from the manufacturer or your attending physician.

Important

- Do not use the hob if the glass surface is cracked or damaged to prevent the risk of electric shock. Disconnect it from the power supply.
- Ensure that the power cable of a connected electrical appliance near the hob is not in contact with the cooking zones.

Cooking on Induction

The principle of induction cooking is based on magnetic effect.

When you put your cookware on an induction zone and switch it on, the electronic boards in the hob produce induced currents in the base of the cookware and instantly raise its temperature. This heat is then transferred to the food inside the cookware.

The best cookware to use with induction cooking has thick flat bases, as the heat will be better distributed meaning cooking is more even.

Most cookware is compatible with induction cooking.

There are three ways to check the suitability of your cookware:

1. Using a magnet to see if the base of the pan is magnetic: if the magnet sticks, then the cookware is compatible.
2. Place the pan on one of the cooking zones and switch the zone on. If the display continues to show the selected power level then the cookware is compatible. If the display shows “E”, the cookware cannot be used on an induction hob.
3. Check the instructions or packaging of the pans for the symbols indicating suitability for use with induction.

Using your hob

Zones:

1. Front left 2.2 - 3.5kW
220 mm x 190 mm
2. Back left 2.2 - 3.5kW
220 mm x 190 mm
3. Back right 2.2 - 3.5kW
220 mm x 190 mm
4. Front right 2.2 - 3.5kW
220 mm x 190 mm

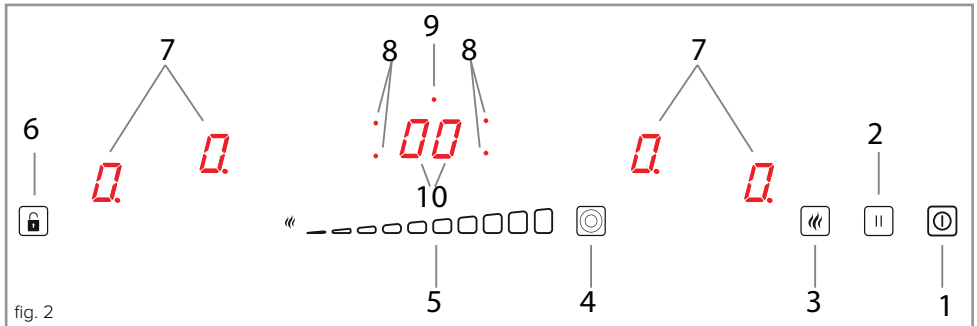
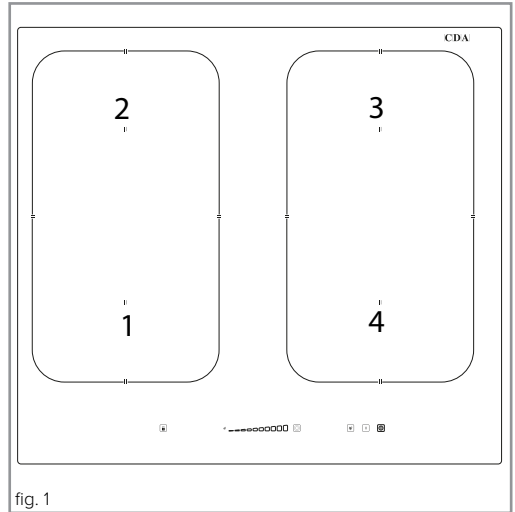

Control panel:

- | | |
|-------------------------------|--------------------------------|
| 1. On/off sensor | 6. Safety Key Lock sensor |
| 2. Pause function sensor | 7. Cooking zone indicators |
| 3. Keep Warm function sensor | 8. Timed zone indicator LEDs |
| 4. Booster function sensor | 9. Minute Minder indicator LED |
| 5. Heat setting slider sensor | 10. Timer indicators |

Using Your Hob

To switch the hob on

- To switch the power on, touch and hold the "On/off sensor" (1)  for approximately one second. The hob will beep and all four cooking zone indicators, and both timer indicators, will show "0".

Please note: If a power level is not set within ten seconds, the hob will switch off automatically.

To activate a zone and set a power level

- Simply touch the desired zone's indicator (7) and then set the desired power level using the heat setting slider sensor (5). The standard power levels range from 1 (minimum) to 9 (maximum). The hob will then begin heating providing that the correct cookware is being used.

Please note: A cooking zone indicator will pulsate when zone control/adjustment is available and will continue to pulsate for approximately 10 seconds after a power level has been set.

To deactivate a zone

- Touch the relevant zone's indicator (7) to activate zone control. You can then use the heat setting slider sensor (5) to return the heat setting to 0. The cooking zone indicator will display a "0" to confirm that the zone is now inactive.
- If switching off multiple zones, the above steps need to be taken for each zone. When all the zones are at "0", the hob will switch off automatically after approximately ten seconds.
- Alternatively, to switch off the hob immediately, touch and hold the

"On/off sensor" (1) for approximately one second.

Please note: Any zones that are still hot to the touch will display an "h" or "H" provided the mains power supply is not interrupted.

Booster

The hob is equipped with a booster function on all zones, allowing a higher power level than the maximum for approximately ten minutes.

To activate the booster on a zone

- Touch the desired zone's indicator (7) and then touch the booster function sensor (5). "P" will show in the cooking zone indicator to show that the booster is on.
- The booster function automatically deactivates after 10 minutes of usage. The cooking zone will continue to operate at its nominal power at this point. The booster can be reactivated after this time provided the hob's internal components have not overheated.

To deactivate the booster on a zone

- To cancel the booster at any time, touch the desired zone's indicator (7) and then use the heat setting slider sensor (5) to return the heat setting to "0".

Please note: The booster function can be used on a pair of bridged cooking zones at the same time. However the booster function cannot be used on more than two zones (or one bridge) at once. This is to prevent damage to the internal components which may be caused by overheating.

If the appliance's electronic circuits or induction coils overheat whilst the booster function is in operation then the function will be automatically deactivated and the zone will continue to operate at its nominal power. The booster function will be available again once the internal components have been cooled sufficiently.

It is normal for a high pitched whirring noise to begin whilst the booster function is in use. This is the cooling fan inside the hob keeping the internal components as cool as possible.

If a pot is removed from the cooking zone whilst the booster function is in use, the ten minute countdown continues.

Operating time limiter

In addition to the booster deactivation timer, each zone has an operating time limiter to increase overall efficiency and to prevent the hob from being left on indefinitely. If a zone's heat setting is not changed for a specific duration then the associated zone is automatically switched off and residual heat indicator activated. Zones can still be used as normal in accordance with the operating instructions. The operating time limiter is set according to the last selected heat setting. The maximum operating times for each setting can be found below.

Zone Heat Setting		1	2	3	4	5	6	7	8	9	P
Maximum Operating Time (hours)	8	8	8	5	5	5	1.5	1.5	1.5	1.5	0.16

Auto-heat Function

- Every zone is equipped with an auto-heat function, which reduces the warming up time for the zone.

To activate the auto-heat function on a zone

- Simply touch the desired zone's indicator (7) and then set the desired power level using the heat setting slider sensor (5).
- Touch the relevant zone's indicator once more. The display will alternate between the set power level and "A" for a preset period of time, before reducing the power to the originally selected heat setting. The duration of each auto-heat setting's limiter is shown in the table below.

To deactivate the auto-heat function

- Simply touch the desired zone's indicator (7) and then either set the desired power level using the heat setting slider sensor (5) to "0" or, alternatively, touch the zone's indicator again to deactivate the auto-heat function and return the zone to the originally set power level.

Zone Heat Setting	1	2	3	4	5	6	7	8	9	P
Maximum Operating Time (seconds)	50	70	135	210	260	430	120	190	--	--

Please note: The auto-heat function is not compatible with heat settings 9 or P (Boost).

Timer/Minute Minder

The hob is equipped with a timer that allows a finish time to be set for the end of cooking on any zone, between a minimum of 1 minute and a maximum of 99 minutes. This timer can be used separately for each zone, and an LED will indicate the zone positions for each of the active timers. Once the timers are set, the timer display will show the time remaining on the first zone to finish cooking. In normal use, the timer ending prompts the zone heating to end as well. However the timer can also be used as a minute minder to count down time without halting heating.

Please note: At the end of the timer, the selected zone will switch off and the timer indicators, and relevant timed zone LED, will flash. The hob will beep for approximately two minutes. To switch off the beep and the flashing display, touch any key. This beeping also occurs after the minute minder time has elapsed and the same process to switch off the beep applies.

To set the timer

- First switch on the hob if necessary and set the desired zone to the power level required.
- With the cooking zone indicator of the selected zone pulsating, touch the timer indicators (10). The second 0 of the timer indicators should pulsate. Use the heat setting slider sensor (5) to set the individual minutes.
- Next, touch the timer indicators (10) to change adjustment to the tens of minutes. The first 0 of the timer indicators should pulsate. Use the heat setting slider sensor (5) to set the tens of minutes.

- After approximately 10 seconds the selection will confirm and the time will begin counting down.
- The timed zone LEDs are oriented in a similar way to the zones;

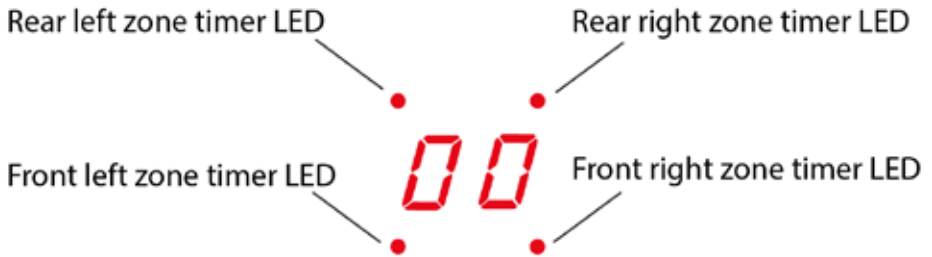

- If no time is set within ten seconds, the timer indicators (10) will become inactive and the zone will continue cooking.

Please note: the timer duration can be adjusted at any time during the countdown. Simply follow the steps for setting the timer and amend the minutes as necessary.

To cancel the timer

- Touch the relevant cooking zone indicator (7) so that the display pulsates. Then touch the timer indicators so that the second 0 pulsates. Use the heat setting slider sensor (5) to change the individual minutes to 0. Touch the timer indicators again so that the first 0 pulsates and use the heat setting slider sensor (5) to set the tens of minutes to 0. The selection will confirm after approximately 10 seconds.
- Do this for each zone if necessary.
- Cancelling the timer will not switch off a zone. You should switch the zone off manually if required.

To set the minute minder

- Switch the hob on using the on/off sensor (1) if necessary but do not set a power level on any zone.
- Touch the timer indicators (10) to activate the minute minder. The LED immediately above the timer indicators should illuminate. This is the minute minder LED. The second 0 of the timer indicators should pulsate. Use the heat setting slider sensor (5) to set the individual minutes.
- Next, touch the timer indicators (10) to change adjustment to the tens of minutes. The first 0 of the timer indicators should pulsate. Use the heat setting slider sensor (5) to set the tens of minutes.
- After approximately 10 seconds the countdown will begin. Heating zones can now be used as normal

To cancel the minute minder

- Follow the steps for setting the minute minder but set the time to 0. After approximately 10 seconds the timer display will extinguish.

Please note: the minute minder will not be available if you try to set it and a zone is already active. All zones must first be inactive/set to 0. Once the minute minder has been set then zones can be used as normal.

Pause Function

The hob is equipped with a pause function that allows the user to suspend the hob's operation for a brief period of time and to easily continue cooking when convenient from the previously assigned settings. This is particularly useful when your attention is drawn from

the hob, i.e. answering the door.

To activate the pause function

- At least one hob zone must be active. Press the pause function sensor (2). All cooking zone indicators will show a pause symbol and zone operation will halt.

To deactivate the pause function and resume cooking

- Press the pause function sensor (2) again. The zones that were operating when the pause function was activated should return to their previously assigned power levels.

Please note: the pause function can only be used for a maximum of 10 minutes. If the hob is not reactivated within this time then the hob switches itself off.

Keep Warm Function

Each zone is equipped with a keep warm function that is designed to keep food at a stable temperature. This allows for the serving of food to be delayed and also for the melting of butter or chocolate.

- A flat-bottomed pan must be used so that the temperature can be accurately measured by the detector within the heating zone.
- Due to the potential for the spread of bacteria it is not advisable to keep food warm for more than two hours.
- There are three temperature levels that can be set: 42°C, 70°C and 94°C.

To activate the keep warm function

- Touch the desired zone's indicator (7). Then touch the keep warm sensor (3) either once, twice or three times.
- Touching the keep warm sensor (3) once will activate the 42°C heating level.
- Touching the keep warm sensor (3) twice will activate the 70°C heating level.
- Touching the keep warm sensor (3) three times will activate the 94°C heating level.
- The selection will confirm after approximately 10 seconds.

Please note: The cooking zone indicator will display the (—) symbol when the 42°C heating level is active, the (≡) symbol will be displayed when the 70°C heating level is active and the (≡) symbol will be displayed when the 94°C heating level is active.

To deactivate the keep warm function

- Touch the relevant zone's indicator (7) and use the heat setting slider sensor (5) to change the power level to 0. The selection will confirm after approximately 10 seconds.

Please note: Any zones that are still hot to the touch will display an "h" or "H" provided the mains power supply is not interrupted.

Bridge Function

The hob is equipped with a bridge function which allows you to use two heating zones with just one zone's controls. This function is intended for use with pans such as fish kettles and is available for the two zones on the left side and the two zones on the right side.

To bridge the left-hand zones

Touch the cooking zone indicator (7) of the front-left zone and, at the same time, touch the cooking zone indicator (7) of the rear-left zone. If the bridge function has been enabled successfully, the cooking zone indicator (7) of the rear-left zone will display a (L7) symbol. The front left zone controls will now alter both zones' heat setting.

To bridge the right-hand zones

Touch the cooking zone indicator (7) of the rear-right zone and, at the same time, touch the cooking zone indicator (7) of the front-right zone. If the bridge function has been enabled successfully, the cooking zone indicator (7) of the rear-right zone will display a (L7) symbol. The front right zone controls will now alter both zones' heat setting.

To cancel a bridge

Simply touch and hold the cooking zone indicator displaying the (L7) symbol for approximately three seconds. If the bridge has been successfully cancelled then the two zone indicators that were bridged will each display a 0. The zones will now be individually operational.

Please note: Pans placed on bridged zones must always cover both the vertical markings (II) on the zones.

Safety Key Lock

To prevent accidental use, the hob has a safety key lock which switches controls off temporarily or completely. The safety key lock can be activated when the hob is turned on but not when power has been switched off at, or the appliance disconnected from, the mains. Disconnecting the appliance from the mains will deactivate the safety key lock.

To switch on the lock, turn on the hob and touch the safety key lock sensor (6) for approximately 4 seconds. The hob will beep and the safety key lock LED should illuminate.

To switch off the lock, switch on the hob if necessary and then touch the safety key lock sensor (6) for approximately 4 seconds. The hob will beep and the safety key lock LED should extinguish.

Residual Heat Indicator

The hob is equipped with residual heat indicators to warn when any of the zones are still hot to the touch after use. An “**h**” will show in a zone’s indicator if the relevant zone is between 45°C and 60°C. An “**H**” will show if the relevant zone is 60°C or above. You should avoid touching any zone whilst the hob is in use or whilst either residual heat indicator is displayed.

In the event of a power cut or failure, the residual heat indicators will illuminate after the power supply is restored. When there is no power supply to the hob however the residual heat indicators will not work, yet the hob zone(s) may still be hot, so extra care must be taken.

Efficient Use of Your Hob

The hob is equipped with zones designed to accommodate most shapes and sizes of pan. For best results, only use pans with flat bottoms. The most efficient use of the hob is shown below, where the pan and zone are correctly chosen.

Use pan lids where possible to minimize the energy usage of your appliance.

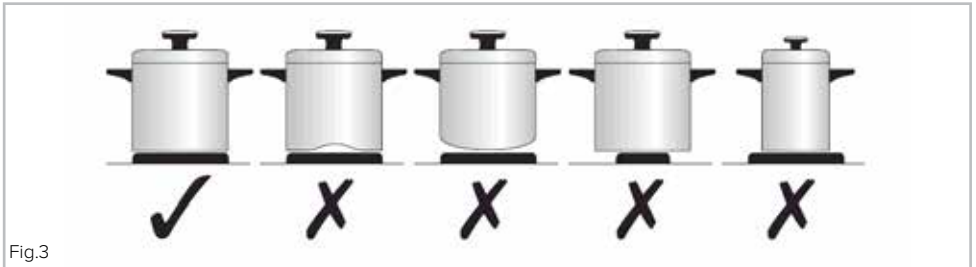

Zone Size	Minimum Pan Size (mm)	Maximum Pan Size (mm)
220mm x 190mm	120	220

Pans placed on the zones must always cover the vertical markings (||) on a zone. Locating the centre of a pan on the zone markings will ensure optimum efficiency.

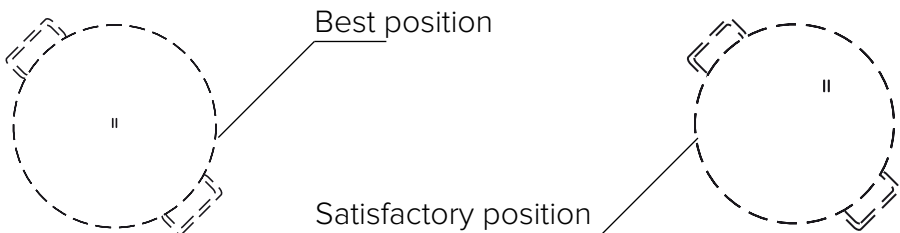

It is very important that the pans used on the hob are made of a suitable material and have the correct type of base. The base of the pan and the hob top must be clean before use to prevent any scratches on the hob top.

Please note: Extra care should be taken if cast iron pans are used as these have coarse bases which may damage the hob top.

Care and Maintenance

Always disconnect the appliance from the power supply before undertaking any cleaning or maintenance.

Important:

- Steam cleaners must not be used when cleaning this appliance.
- You should use a non-abrasive cleaner to clean the hob top. Any abrasive cleaner (including Cif) will scratch the surface and could erase the control panel markings.
- Sugar and starch can cause permanent damage to the surface of the hob. Wipe away any spillages immediately but be careful given that the hob top will be hot during and after usage.
- Avoid letting pans boil over where possible to ensure that the need for cleaning is minimal.
- Always use a soft sponge or cloth where possible. Utensils such as scouring sponges and some brushes could cause scratches to the hob top.

A cleaning guide is available on page 21.

Type of residue	Clean with	Cleaning advice
Light	Cleaning sponge and soft cloth	Wipe over the zone to be cleaned with a sponge and hot water, and then wipe off with a soft dry cloth.
Accumulated baked-on stains/dirt, sugar spills or melted plastics	Cleaning sponge or glass scraper and soft cloth	Wipe over the zone to be cleaned with a sponge and hot water, using a ceramic scraper to remove any large marks or stains and then wipe off with a soft dry cloth.
Rings and hard water residues	White vinegar and soft cloth	Pour a small amount of warm white vinegar onto the stain, leave it to stand, and then wipe off with a soft dry cloth.
Shiny metallic streaks	Cleaning agent for vitroc ceramic glass etc.) Slow boiling, e.g. spaghetti, soups, stews, potatoes	Use specialist vitroc ceramic glass cleaner (preferably one with silicone for its protective properties)

If your hob is not working:

1. Check that the zone is switched on.
2. Check that the mains supply has not been switched off.
3. Check that the fuse in the spur has not blown.

In the event of a fault with the hob please advise CDA Customer Care.

Contact CDA Customer Care

A: Customer Care Department, The CDA Group Ltd, Harby Road,
Langar, Nottinghamshire, NG13 9HY

T: 01949 862 012 F: 01949 862 003

E: customer.care@cda.eu W: www.cda.eu

Troubleshooting

Problem	Possible Causes	Possible Remedy
The appliance does not work and no indicators are lit.	The appliance has no power	Check the fuse and replace if blown.
Sensor fields do not respond when touched.	Appliance is not turned on	Turn on the appliance
	A sensor field has been touched too briefly (less than a second)	Touch the sensor field again and for longer
	Multiple sensors have been touched/covered at the same time	Only touch one sensor field at a time unless instructed otherwise
	The safety key lock is engaged	Disengage the safety key lock as per page 18
The appliance does not respond and emits an extended beep	Improper use (wrong sensor fields touched or touched too briefly)	Switch the appliance off via the on/off sensor and at the mains and then switch the power and appliance on again
The appliance switches itself off	No heat level has been set within 10 seconds of activating the appliance	Switch on the appliance and set zone and heat setting without delay
	Sensor fields covered or dirty	Uncover or clean the sensor fields
A cooking zone switches itself off and a residual heat indicator is shown.	Operating time limiter has activated.	Nothing (see pages 10-11)
	Sensor fields covered or dirty	Uncover or clean the sensor fields
	Electronic components have overheated	Nothing. Allow appliance to cool.

Problem	Possible Causes	Possible Remedy
Residual heat indicator has extinguished despite zone(s) still being hot.	The appliance has no power	Check the fuse and replace if blown.
Hob top is broken, cracked and/or chipped.	Stop using the appliance immediately and switch the appliance off at the mains. Contact CDA Customer Care to arrange a repair.	
The appliance makes a buzzing noise.	Buzzing noises are normal whilst the hob is in use (inductor modules functioning) and after the hob has been used (cooling fan in operation).	
The appliance makes noises similar to whistles, hisses and pops.	These noises are normal. If several cooking zones are used at once then the hob can make hissing or whistling noises due to the frequencies used to power the inductor modules. Popping noises can often be heard when pans are being heated.	
cooking zone or multiple zones do not work.	The internal electronics may be faulty and in need of a reset.	Reset the appliance by disconnecting it from the mains for a few minutes before reconnecting it.
One or more zones display a “ <u> </u> ” symbol	The selected pan is not suitable for use with this hob.	See page 6 for more information on selecting a correct pan.

Should any error code show on the zone displays, or the above steps not resolve an issue, please contact CDA Customer Care for assistance. Contact details are on page 21.

IMPORTANT - PLEASE NOTE: In the event of any breakage, crack or cracking – even minimal – of the vitroceramic glass, immediately disconnect your appliance to prevent a risk of electric shock and contact CDA Customer Care.

Fitting the Hob

Unpacking the hob:

Take care not to lose, drop or mishandle any parts.

Fitting position of the hob:

This appliance must be installed a minimum of 55mm away from any adjacent vertical surfaces, e.g. a tall cupboard end panel. This may be reduced to 50mm if the adjacent surface is resistant to fire (tiles or steel for example). These dimensions are shown in Fig.8 on page 27.

Ventilation requirements:

This appliance must be installed to allow air to flow freely to the air intake and from the air outlet. An air gap of 25mm is recommended immediately below the hob.

Failure to allow sufficient ventilation could cause problems with operation or damage to the hob and constitutes incorrect installation, which is not covered by the product's warranty (Figs. 4 and 5).

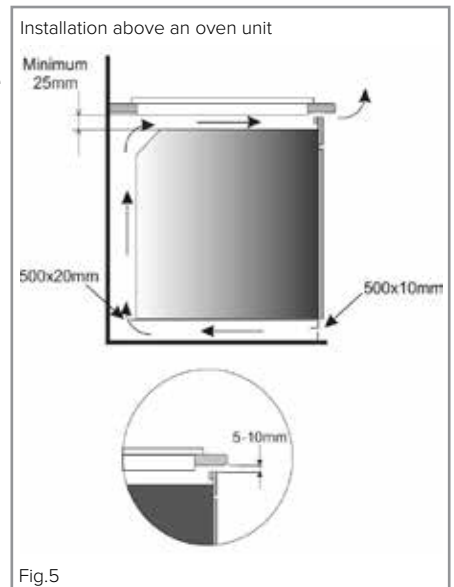
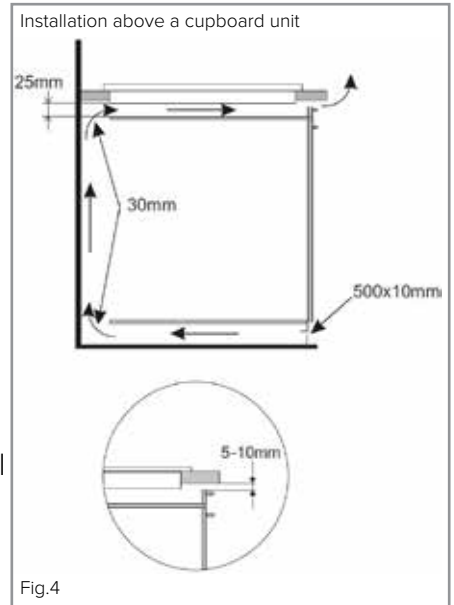

If fitting a cooker hood above the hob:

If a cooker hood is to be installed above the hob, the height of the hood above the hob must be at least 600mm (650mm is recommended) (Fig.6). If the instructions supplied with the hood dictate that the hood must be installed at a height greater than 600mm, then that height is the minimum required.

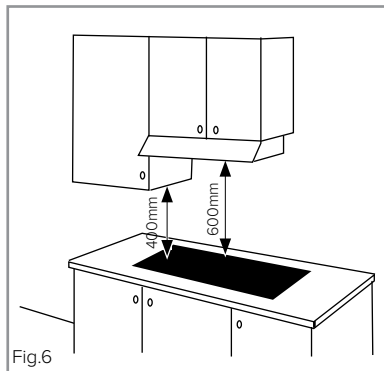

Wall furniture requirements:

The minimum height of any cabinet immediately above the hob is 900mm. The minimum height of any adjacent units (including light pelmets) is 400mm, unless they are manufactured from a material resistant to fire (steel, for example).

Important notes:

- Do not position this appliance above a refrigeration unit. The heat generated may cause the refrigeration unit to fail.
- This appliance is designed to be installed into cabinet units capable of withstanding temperatures of 65°C or greater above ambient temperature.

Important notes:

- Never place perishable foods, cleaning products or flammable items in the cupboard below the appliance.
- If an oven is to be installed below the hob, the thermal safety system on the hob may not allow the hob to be used at the same time as a pyrolytic programme on the oven.
- **Ensure that the top rail is removed prior to installation, and that no unit cross member is blocking the air outlets.**
- If the hob is to be located above a working drawer, we recommend that the drawer is not used for storing soft items, for example dusters or towels; this is to minimize the risk of the cooling system air intakes being obstructed.

How to Install the Hob

Overall dimensions of the hob:

Width: 574 mm Depth: 518 mm

Worktop cut-out dimensions:

Width: 560 mm Depth: 495 mm

1. Make the required hole in the worktop. Before doing this, you must check the instructions supplied with any cooker hood to ensure that you will have the required clearance. The cutout in Fig.8 in shows a minimum of 50mm is required from the back of the cutout to the rear wall or splashback the hob is intended to be situated in front of.

2. Make sure that the worktop is clean and dust free and insert the hob into the cut-out opening. Press the hob firmly into place so that the seal connects with the worktop (Fig. 7).

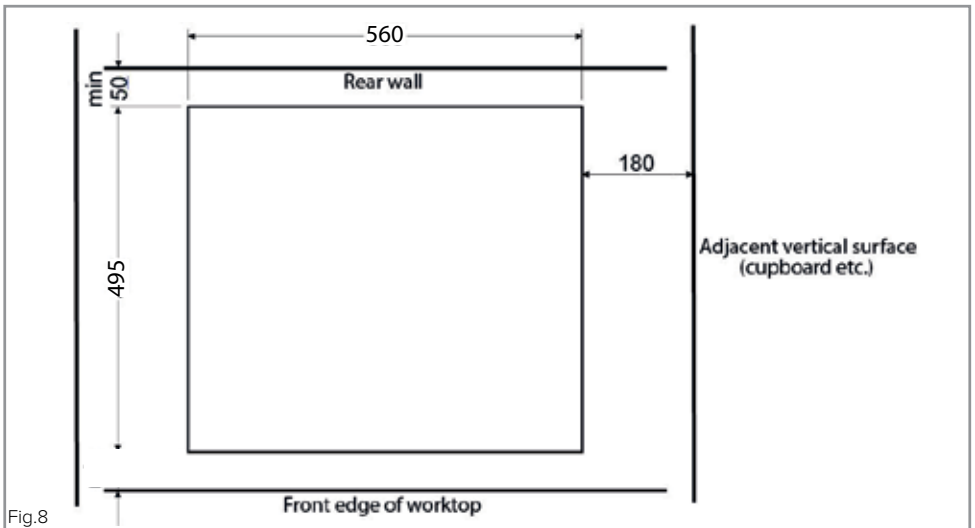
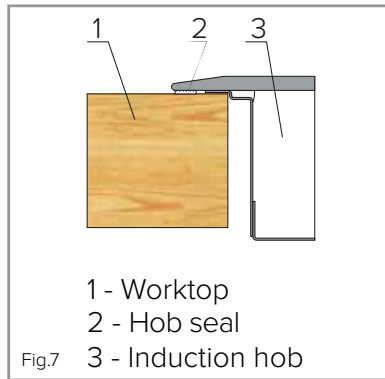

Mains Electricity Connection

Warning! This appliance must be earthed.

We recommend that the appliance is connected by a qualified electrician, who is a member of the N.I.C.E.I.C. and who will comply with the I.E.T. and local regulations.

This appliance is intended to be connected to fixed wiring and is not suitable for connection to a 13A plug or 13A supply.

This appliance is intended to be connected to fixed wiring by a double pole switch, having a contact separation of at least 3mm in all poles. The switch must be positioned no further than 2m from the appliance.

Please note:

- The mains cable must only be replaced by a qualified electrician or service engineer and must be of equivalent or better rating (i.e. 4mm², HO5VV-F).

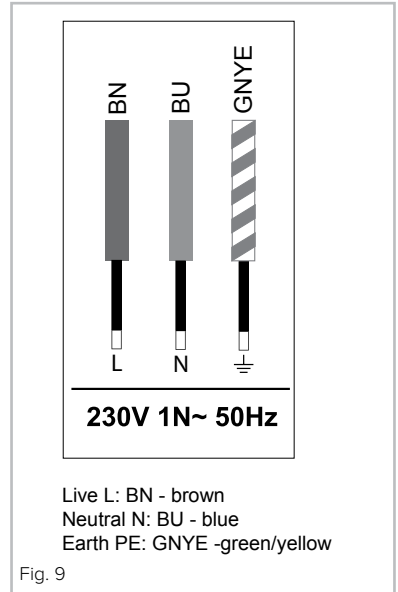

- This appliance is intended to be connected to the mains supply with a cable of cross sectional area 4mm².
- The current rating of the fuse or circuit breaker protecting this appliance should be marked on the socket outlet.
- Assembly and electrical connection should be carried out by specialised personnel.
- When installing this product we recommend you seek the help of another individual.
- **Should the mains cable be damaged or need to be replaced, it should only be done so by a qualified electrician or engineer. The connections to the hob are shown below;**

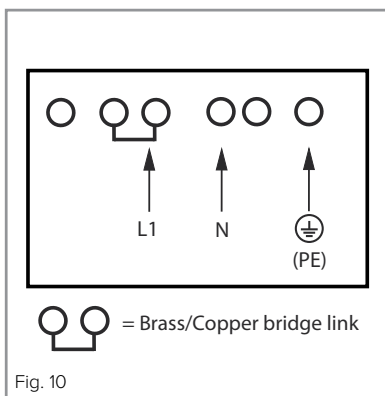

- Ensure that the brass links are securely fitted. Failure to do so may prevent the hob from operating correctly.

Appliance electrical rating: 7400W

NOTES:

Energy Efficiency Information

Attribute	Symbol	Value	Units
CDA model		HN6841FR	
Type of hob		Built in	
Number of cooking zones and/or areas		4	
Heating technology (induction cooking zones and cooking areas, radiant cooking zones, solid plates)		Induction cooking zones	
For circular cooking zones or area: diameter of useful surface area per electric heated cooking zone, rounded to the nearest 5mm	∅	NA	cm
For non-circular cooking zones or areas: length and width of useful surface area per electric heated cooking zone or area, rounded to the nearest 5mm	L x W	FL:22.0 x 19.0/ FR:22.0 x 19.0/ RL:22.0 x 19.0/ RR:22.0 x 19.0	cm
Energy consumption per cooking zone or area calculated per kg	EC <small>Electric cooking</small>	FL:188.9/ FR:188.9/ RL:188.9/ RR:188.9/	Wh/kg
Energy consumption for the hob calculated per kg	EC <small>Electric hob</small>	188.9	Wh/kg



Please contact our **Customer Care Department** for Service on the details below

Customer Care Department

The ICDAI Group Ltd. • Harby Road • Langar • Nottinghamshire • NG13 9HY
T : 01949 862 012 F : 01949 862 003 E : customer.care@cda.eu

