

HG7501..

Built-in

Cooking Hob

Installation, Use and Maintenance



Important

This appliance is designed and manufactured solely for the cooking of domestic (household) food and is not suitable for any non domestic application and therefore should not be used in a commercial environment.

The appliance guarantee will be void if the appliance is used within a non domestic environment i.e. a semi commercial, commercial or communal environment.

The CDA Group Ltd cannot be held responsible for injuries or losses caused by incorrect use or installation of this product. Please note that CDA reserve the right to invalidate the guarantee supplied with this product following incorrect installation or misuse of the appliance.

Appliance Information:

Please enter the details on the appliance rating plate below for reference, to assist CDA Customer Care in the event of a fault with your appliance and to register your appliance for guarantee purposes.

Appliance Model	
-----------------	--

Serial Number	
---------------	--

DECLARATION OF CE CONFORMITY

- This appliance has been designed to be used only for cooking. Any other use (such as heating a room) is improper and dangerous.
- This appliance has been designed, constructed, and marketed in compliance with:
 - Safety requirements of the "Gas" Regulation (EU) 2016/426;
 - Safety requirements of the "Low voltage" Directive 2014/35/EU;
 - Safety requirements of the "EMC" Directive 2014/30/EU;
 - Requirements of EU Directive 93/68/EEC;
 - Requirements of EU Directive 2011/65/EU.



Important Information for Correct Disposal of the Product in Accordance with EC Directive 2012/19/EC.

At the end of its working life, the product must not be disposed of as urban waste. It must be taken to a special local authority differentiated waste collection centre or to a dealer providing this service.

Disposing of a household appliance separately avoids possible negative consequences for the environment and health deriving from inappropriate disposal and enables the constituent materials to be recovered to obtain significant savings in energy and resources. As a reminder of the need to dispose of household appliances separately, the product is marked with a crossed-out wheeled dustbin.



IMPORTANT SAFETY PRECAUTIONS AND RECOMMENDATIONS

IMPORTANT: This appliance is designed and manufactured solely for the cooking of domestic (household) food and is not suitable for any non domestic application and therefore should not be used in a commercial environment.

The appliance guarantee will be void if the appliance is used within a non domestic environment i.e. a semi commercial, commercial or communal environment.

Read the instructions carefully before installing and using the appliance.

- This appliance has been designed and manufactured in compliance with the applicable standards for the household cooking products and it fulfills all the safety requirements shown in this manual, including those for surface temperatures.
Some people with sensitive skin may have a more pronounced temperature perception with some components although these parts are within the limits allowed by the norms.
The complete safety of the appliance also depends on the correct use, we therefore recommend to always pay a extreme attention while using the product, especially in the presence of children.
- After having unpacked the appliance, check to ensure that it is not damaged.
In case of doubt, do not use it and consult your supplier or a professionally qualified technician.
- Packing elements (i.e. plastic bags, polystyrene foam, nails, packing straps, etc.) should not be left around within easy reach of children, as these may cause serious injuries.
- Some appliances are supplied with a protective film on steel and aluminium parts. This film must be removed before using the appliance.
- **IMPORTANT:** The use of suitable protective clothing/gloves is recommended when handling or cleaning this appliance.
- Do not attempt to modify the technical characteristics of the appliance as this may become dangerous to use. The manufacturer declines all responsibility for any inconvenience resulting from the inobservance of this condition.

- **CAUTION:** this appliance must only be installed in a permanently ventilated room in compliance with the applicable regulations.
- Do not carry out cleaning or maintenance operations on the appliance without having previously disconnected it from the electric power supply.
- Do not use a steam cleaner because the moisture can get into the appliance therefore making it unsafe.
- Do not cover the hob with aluminium foils.
- Do not touch the appliance with wet or damp hands (or feet).
- Do not use the appliance whilst in bare feet.
- If you should decide not to use this appliance any longer (or decide to substitute another model), before disposing of it, it is recommended that it be made inoperative in an appropriate manner in accordance to health and environmental protection regulations, ensuring in particular that all potentially hazardous parts be made harmless, especially in relation to children who could play with unused appliances.
- The various components of the appliance are recyclable. Dispose of them in accordance with the regulations in force in your country. If the appliance is to be scrapped, remove the power cord.
- After use, ensure that the knobs are in the off position.
- Children less than 8 years of age shall be kept away unless continuously supervised.
- This appliance can be used by children aged from 8 years and above and persons with reduced physical, sensory or mental capabilities or lack of experience and knowledge if they have been given supervision or instruction concerning use of the appliance in a safe way and understand the hazards involved. Children shall not play with the appliance. Cleaning and user maintenance shall not be made by children without supervision.
- The manufacturer declines all liability for injury to persons or damage to property caused by incorrect or improper use of the appliance.
- **WARNING:** During use the appliance and its accessible parts become hot; they remain hot for some time after use.
 - Care should be taken to avoid touching heating elements on the hob.
 - To avoid burns and scalds, young children should be kept away.
- Make sure that electrical cables connecting other appliances in the proximity of the cooktop cannot come into contact with the hob.

- **WARNING:** Unattended cooking on a hob with fat or oil can be dangerous and may result in fire. NEVER try to extinguish a fire with water, but switch off the appliance and then cover flame e.g. with a lid or a fire blanket.
- **WARNING:** Danger of fire: do not store items on the cooking surfaces.
- Do not place or leave empty pans on the glass ceramic hob.
- Do not allow heavy or sharp objects to drop on the glass ceramic hob.
- Do not scratch the hob with sharp objects. Don't use the hob as a work surface.
- **WARNING:** If the hob is cracked or otherwise damaged by falling objects etc., disconnect the appliance from the electrical power supply to avoid the possibility of electric shock and call Customer Service.
- **WARNING:** When correctly installed, your product meets all safety requirements laid down for this type of product category. However special care should be taken around the underneath of the appliance as this area is not designed or intended to be touched and may contain sharp or rough edges, that may cause injury.
- **CAUTION:** The cooking process has to be supervised. A short term cooking process has to be supervised continuously.
- If the power supply cable is damaged, it must be replaced only by an authorized service agent in order to avoid a hazard.
- If the appliance is not fitted with a supply cord and a plug, or with other means for disconnection from the supply mains having a contact separation in all poles that provide full disconnection under overvoltage category III conditions, means for disconnection must be incorporated in the fixed wiring in accordance with the wiring rules.
- **WARNING:** The appliance and its accessible parts become hot during use.
Care should be taken to avoid touching heating elements.
Children less than 8 years of age shall be kept away unless continuously supervised.
- **WARNING:** Use only hob guards designed by the manufacturer of the cooking appliance or indicated by the manufacturer of the appliance in the instructions for use as suitable or hob guards incorporated in the appliance. The use of inappropriate guards can cause accidents.

ENERGY LABELLING/ECODESIGN

- Commission regulation (EU) No 66/2014 (implementing Directive 2009/125/EC of the European Parliament and of the Council).

Reference to the measurement and calculation methods used to establish compliance with the above requirements:

- Standard EN30-2-1 (hobs: gas fired burners).

USE OF THE APPLIANCE, ENERGY SAVING TIPS

HOB

GAS FIRED BURNERS

- It is important that the diameter of the pot be suitable to the size of the burner so as not to compromise the high output of the burners and therefore energy waste. A small pot on a large burner does not give you a boiling point in a shorter amount of time since the capacity of heat absorption of a liquid mass depends on the volume and the surface of the pot.
- Avoid keeping a burner on without something on it (without pot).

ADVICE
for the
INSTALLER

IMPORTANT :

- The appliance is designed and approved for domestic use only and should not be installed in a commercial, semi commercial or communal environment.

Your product will not be guaranteed if installed in any of the above environments and could affect any third party or public liability insurances you may have.

The appliance may be installed in a kitchen, kitchen/diner or a bed sitting room, but not in a room or space containing a bath or a shower without first consulting current regulations.

The appliance must not be installed in a bed-sitting room of less than 20 m³.

- This appliance is to be installed, regulated and adapted to function only by an authorized person in compliance with the current local regulations in force and in observation of the instructions supplied by the manufacturer.

Failure to comply with this condition will render the guarantee invalid.

The appliance installation must only be carried out by a **SUITABLY QUALIFIED AND REGISTERED TECHNICIAN** and in compliance with local safety standards.

Failure to observe this rule will invalidate the warranty.

- The appliance must be installed in compliance with regulations in force in your country and in observation of the manufacturer's instructions.
- Installation technicians must comply to current laws in force concerning ventilation and the evacuation of exhaust gases.
- Incorrect installation, for which the manufacturer accepts no responsibility, may cause personal injury or damage.
- This appliance shall only be serviced by authorized personnel.
- Always disconnect the appliance from mains power supply before carrying out any maintenance operations or repairs.

- **Important: The use of suitable protective clothing/gloves is recommended when handling or cleaning of this appliance.**
- **These tops are designed to be embedded into kitchen fixtures measuring 600 mm in depth, working surface 30 to 40 mm thick.**
- **The appliance must be housed in heat-resistant units.**
- **The walls of the units must not be higher than work top and must be capable of resisting temperatures of 105°C above room temperature.**
- **We would point out that the adhesive which bonds the plastic laminate to the furniture must withstand temperatures not less than 150°C to avoid delamination.**
- **Do not install the appliance near inflammable materials (eg. curtains).**

WARNING!

When correctly installed, your product meets all safety requirements laid down for this type of product category. However special care should be taken around the underneath of the appliance as this area is not designed or intended to be touched and may contain sharp or rough edges, that may cause injury.

Installation

TECHNICAL INFORMATION FOR THE INSTALLER

In order to install the cooker top into the kitchen fixture, a hole with the dimensions shown in fig. 15a has to be made, bearing in mind the following:

- A 40mm ventilation gap must be provided between the bottom of the appliance and any cabinetry, draw unit, thermal protection barrier or appliance.
- If the cooktop is installed directly above an oven (which does not have a cooling fan motor) or if its base is accessible through a cupboard or drawer space after installation, a thermal protection barrier must be installed below the base of the cooktop as indicated in fig. 1c.
- If the oven installed below the cooktop has a cooling fan motor, the thermal protection barrier is not required.
- If the cooktop is installed above an oven, the two appliances shall be connected to the gas and/or electrical supply with independent connections.
- The cooker top must be kept no less than 200 mm away from any side wall (from side edge of cutout - figs. 1a, 1b).
- The hob must be installed at least 60 mm from the wall (from rear edge of cutout - fig. 1a).
- There must be a distance of at least 650 mm between the hob and any wall cupboard or extractor hood positioned immediately above (see fig. 1b).

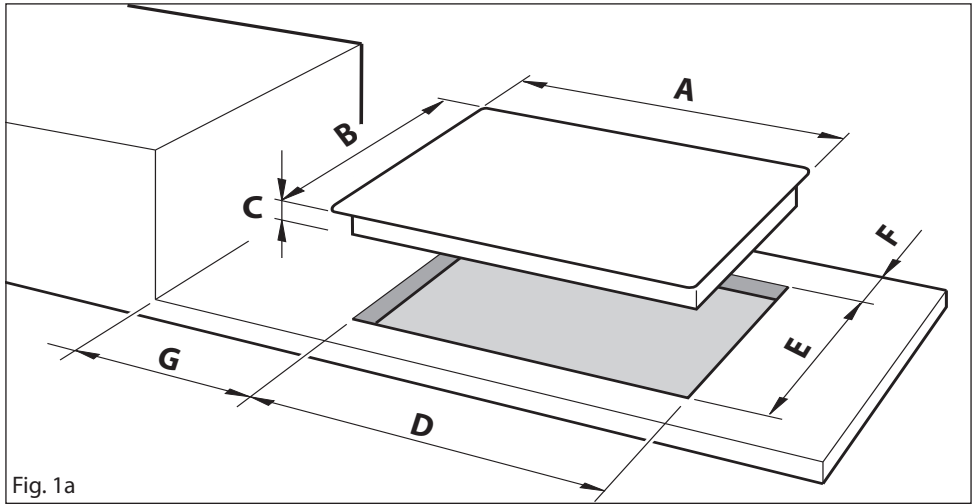

Fig. 1a

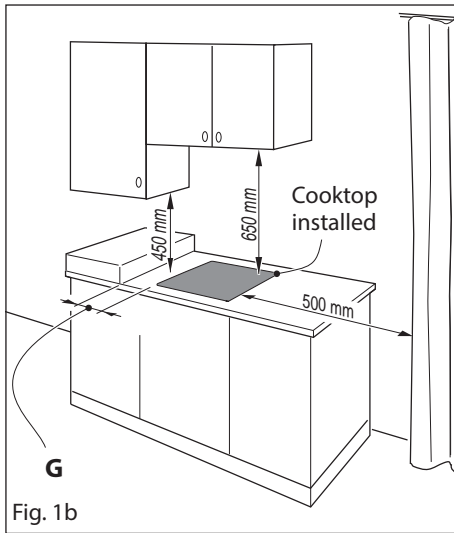

Fig. 1b

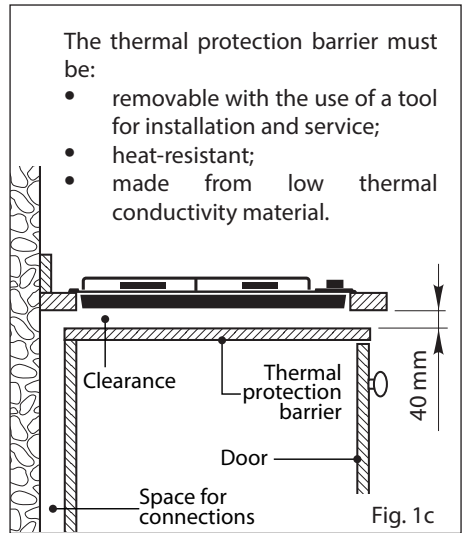

Fig. 1c

The thermal protection barrier must be:

- removable with the use of a tool for installation and service;
- heat-resistant;
- made from low thermal conductivity material.

Measures (mm)

Description	Measures (mm)						
	A	B	C	D	E	F (minimum)	G (minimum)
75cm wide model	750	510	49	560	480	60	200

FASTENING THE COOKTOP

Each cooktop is provided with an installation kit including brackets and screws for fastening the cooktop to benches from 30 to 40mm thick.

The kit includes two "F" type brackets (for the front of the cooktop), two "R" type brackets (for the rear of the cooktop) and four self-threading screws "S".

- Cut the unit according to the dimensions in fig. 2a.
- Stretch gasket "G" over the edge of the hole made, being careful to overlay the junction edges.
- Fasten the brackets "F" and "R" to the appropriate socket holes, without tightening the screws "S" for the moment. Make sure that the tabs are mounted correctly, as shown (figs. 2b, 2c). Rotate the tabs so that the cooktop can be put into the cutout.
- Put the cooktop into the cutout and position it correctly.
- Put the brackets "F" and "R" into place; tooth "A" of the brackets should go into the hole (figs. 2b, 2c).
- Tighten screws "S" until the cooktop is completely secured to the bench.
- Using a sharp cutter or trimmer knife, trim the excess sealing material around the edge of the cooktop.
Take care not to damage the workbench.

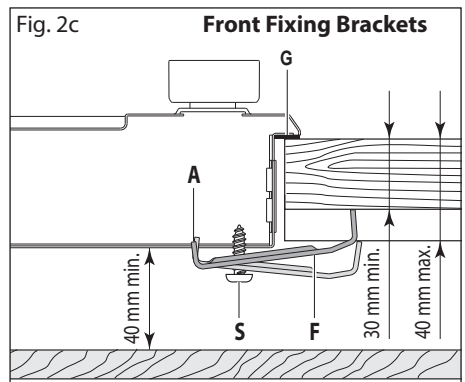
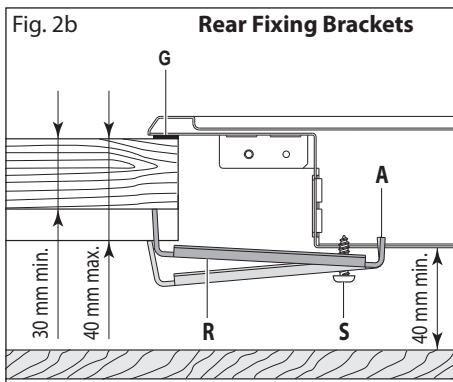
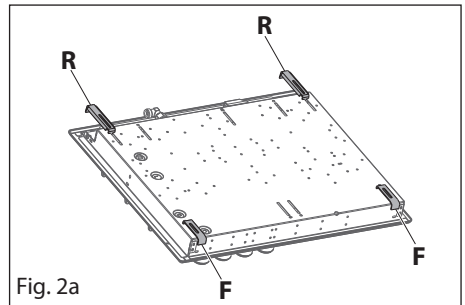

PROVISION FOR VENTILATION

- The appliance should be installed into a room or space with an air supply in accordance with the current version of BS 5440-2: 2000.
- For rooms with a volume of less than 5m³ - permanent ventilation of 100 cm² free area must be provided.
- For rooms with a volume of between 5 m³ and 10 m³ a permanent ventilation of 50 cm² free area will be required unless the room has a door which opens directly to the outside air in which case no permanent ventilation is required.
- For rooms with a volume greater than 10 m³ - no permanent ventilation is required.

Note: Regardless of room size, all rooms containing the appliance must have direct access to the outside air via an openable window or equivalent.

- Where there are other fuel burning appliances in the same room, the current version of BS 5440-2: 2000 should be consulted to determine the correct amount of free area ventilation requirements.

Gas Section

GAS INSTALLATION REQUIREMENTS

Important !

- **Before installation, make sure that the local distribution conditions (gas type and pressure) and the adjustment of this appliance are compatible. The appliance adjustment conditions are given on the plate or the label.**
- **This appliance must be installed and serviced only by a suitably qualified, registered installer with technical knowledge of both gas installation and electricity. The installation or service must comply with the current editions of the applicable standards, regulations, and codes of practice governing gas and electrical installations.**
- **Failure to install the appliance correctly could invalidate any manufacturer's warranty.**

This appliance is supplied for use on NATURAL GAS or LPG (check the gas regulation label attached on the appliance).

- Appliances supplied for use on NATURAL GAS: they are adjusted for this gas only and cannot be used on any other gas (LPG) without modification. The appliances are manufactured for conversion to LPG.
- Appliances supplied for use on LPG: they are adjusted for this gas only and cannot be used on any other gas (NATURAL GAS) without modification. The appliances are manufactured for conversion to NATURAL GAS.

If the NATURAL GAS/LPG conversion kit is not supplied with the appliance this kit can be purchased by contacting the After-Sales Service.

INSTALLATION & SERVICE REGULATIONS

It is a legal requirement that all gas appliances are Installed & Serviced by a competent person in accordance with the current editions of the following Standards & Regulations or those regulations appropriate to the geographical region in which they are to be installed:

- Gas Safety (Installation & Use) Regulations
- Building Regulations
- British/European Standards
- Regulations for Electrical Installation

Installation and service of any gas product must be made by a suitably qualified and registered person competent on the type of product being installed or serviced and holding a valid certificate of competence for the work being carried out. Currently the proof of competence is the Accredited Certification Scheme (ACS) or N/SVQ that has been aligned to the ACS.

It is also a requirement that all businesses or self employed installers are members of a class of person approved by the Health and Safety Executive.

Failure to install the appliance correctly could invalidate any manufacturers warranty and lead to prosecution under the above quoted regulations.

GAS CONNECTION



Installation to Natural Gas

Installation to Natural Gas must conform to the Code of Practice, etc.

The supply pressure for Natural Gas is 20 mbar.

The installation must conform to the relevant British/European Standards.

Installation to LP Gas

When operating on Butane gas a supply pressure of 28-30 mbar is required.

When using Propane gas a supply pressure of 37 mbar is required.

The installation must conform to the relevant British/European Standards.

Warning: Only a suitably qualified and registered installer, also with technical knowledge of electricity should install the appliance.

He should observe the Regulations and Codes of Practice governing such installation of gas appliances.

Note: It is recommended that the gas connection to the appliance is installed with a flexible hose connecting tube made to BS669 or EN 14800.

Notes:

- **Flexible hoses can be used where the sited ambient temperature of the hose does not exceed 70°C. These hoses must be manufactured in accordance with BS669 part 1 or EN 14800 and be of the correct construction for the type of gas being used.**
- **Gas hoses designed for natural gas MUST NOT be used for supplying LPG gas (LPG gas hoses can be identified by a either a red band or stripe on the rubber outer coating of the hose).**
The hose should not be crushed or trapped or be in contact with sharp or abrasive edges.

IMPORTANT! It is the responsibility of the gas installer to ensure that the product is fully tested and commissioned in accordance with current regulations to ensure there are no gas escapes.

The fitting (fig. 3) is made up of:

- 1 nut “A”
- 1 elbow fitting “C”
- gasket “F”

Connection to the Gas Supply

- Be careful when flexible pipes are used that they do not come into contact with moving parts.
- To maintain the thickness of 3 cm, the hob is fitted with a channel to contain the connection pipe.
- The gas inlet union can be turned in the direction required after the elbow fitting “C” and nut “A” connection (figure 3) has been slackened (fig. 4).
- Never put it in the horizontal or vertical position.
- Never attempt to turn the elbow “C” without having first slackened off the relative lock nut “A”.
- The gasket “F” (fig. 3) guarantees the seal of the gas connection. It is recommended that it be replaced whenever it shows even the slightest deformation or imperfection.

If installation is to be carried out using a flexible connector (to BS669 or EN14800), then the following points must be adhered to:

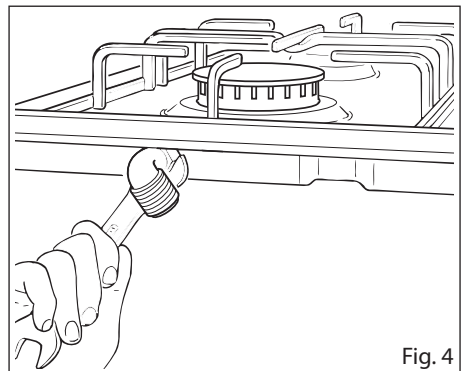
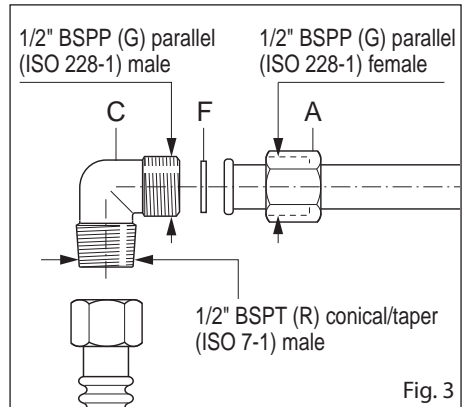

Note: The gas installation pipes and the final connection to the appliance connecting pipe shall be of a sufficient size to maintain the heat output of the appliance as specified on the rating plate.

1. The appliance flexible connector should not be subject to undue forces, either in normal use whilst being connected or disconnected.
2. The appliance flexible connector should not be subject to excessive heat by direct exposure to flue products or by contact with hot surfaces.
3. The socket into which the plug of the appliance flexible connector fits should be permanently attached to a firmly fixed gas installation pipe and positioned such that the hose hangs freely downwards in a natural loop and does not touch the floor.
4. The appliance flexible connector should be positioned such that it will not suffer mechanical damage; eg abrasion from the surrounding kitchen furniture which may be moved in use, such as a door or drawer, or by being trapped by a stability device.
5. The bayonet fitting should be accessible for disconnection after moving the appliance.



GAS MAINTENANCE

TABLE FOR THE CHOICE OF THE INJECTORS

  Cat: II 2H 3+			G30/G31 28-30/37 mbar	G20 20 mbar
BURNERS	Nominal Power [kW]	Reduced Power [kW]	Ø injector [1/100 mm]	Ø injector [1/100 mm]
Auxiliary (A)	1,00	0,40	50	77
Semi-rapid (SR)	1,75	0,45	66	101
Triple-ring (TR)	3,80	1,50	98	141
Dual (DB) - inner crown	0,80	0,40	46	70
Dual (DB) - outer crown	3,40	1,50	65 (x2)	95 (x2)

AIR VENT NECESSARY FOR GAS COMBUSTION = $(2 \text{ m}^3/\text{h} \times \text{kW})$

BURNERS	Air necessary for combustion [m ³ /h]
Auxiliary (A)	2,00
Semi-rapid (SR)	3,50
Triple-ring (TR)	7,60
Dual (DB) - inner crown only	1,60
Dual (DB) - outer crown only	6,80
Dual (DB) - inner & outer crown	8,40

LUBRICATION OF THE GAS TAPS

In case of difficulty in the gas taps operation, call Service.

IMPORTANT

All intervention regarding installation, maintenance and conversion of the appliance must be fulfilled with original factory parts.

The manufacturer declines any liability resulting from the non-compliance of this obligation.

REPLACEMENT OF THE INJECTORS

If the injectors are not supplied they can be obtained from the "Service Centre".

Select the injectors to be replaced according to the "TABLE FOR THE CHOICE OF THE INJECTORS".

The nozzle diameters, expressed in hundredths of a millimeter, are marked on the body of each injector.

REPLACEMENT OF THE INJECTORS OF THE COOKTOP BURNERS

To replace the injectors proceed as follows:

- Remove pan supports and burners from the cooktop.
- Using a wrench, substitute the injectors "J" (figs. 5a, 5b, 5c) with those most suitable for the kind of gas for which it is to be used.

The burners are conceived in such a way so as not to require the regulation of the primary air.

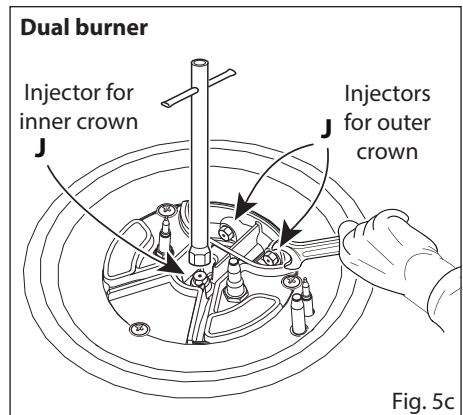
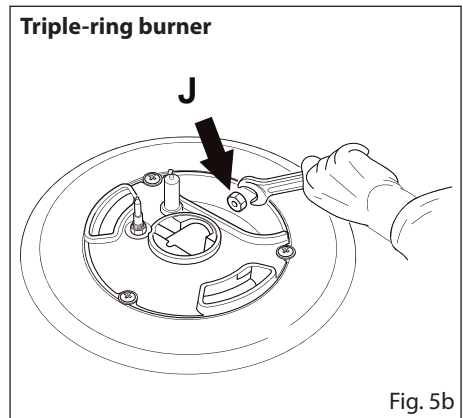
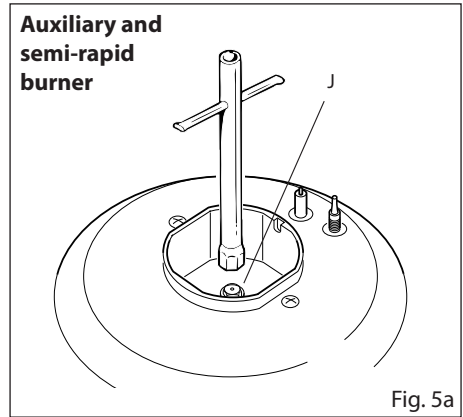

SETTING THE MINIMUM OF THE COOKTOP BURNERS

In the minimum position the flame must have a length of about 4 mm and must remain lit even with a quick turn from the maximum position to that of minimum.

The flame adjustment is done in the following way:

- Turn on the burner.
- Turn the tap to the 'MINIMUM' position.
- Take off the knob.
- With a small flat screwdriver turn the screw "A" to the correct regulation (fig. 6).
- For the dual burner set the minimum (as indicated above) for both the gas valves (one for the inner and one for the outer crown). The operations must be carried out one gas valve at a time.

Normally for LPG tighten up the regulation screw.

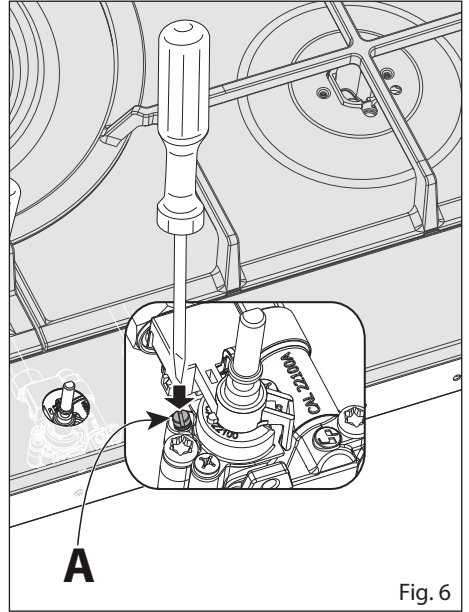

Mains Electricity Connection

Incorrect installation may be dangerous and the manufacturer can not be held responsible. Warning! This appliance must be earthed The manufacturer declines all responsibility for any problem caused by failure to observe this rule.

THIS APPLIANCE MUST BE CONNECTED TO THE MAINS SUPPLY BY A COMPETENT PERSON, USING FIXED WIRING VIA A DOUBLE POLE SWITCHED FUSE SPUR OUTLET AND PROTECTED BY A 3A FUSE.

We recommend that the appliance is connected by a qualified electrician, who is a member of the N.I.C.E.I.C. and who will comply with the I.E.E. and local regulations.

The wires in the mains lead of this appliance are coloured in accordance with the following code:

Green & Yellow = Earth, Blue = Neutral, Brown = Live.

As the colours of the wires in the mains lead for the appliance may not correspond with the coloured markings identifying the terminals connecting to the fuse spur, proceed as follows:

- The wire which is coloured green and yellow must be connected to the terminal marked **E** (Earth) or coloured green.
- The wire which is coloured blue must be connected to the terminal marked **N** (Neutral), or coloured black.
- The wire which is coloured brown must be connected to the terminal marked **L** (Live), or coloured red.

Note: Use a 3A Fuse

Assembly and electrical connection should be carried out by specialised personnel. When installing this product we recommend you seek the help of another individual.

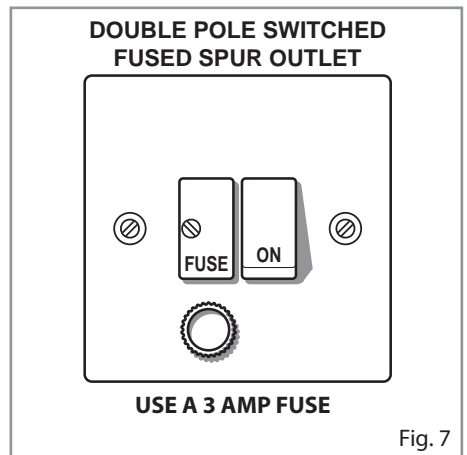
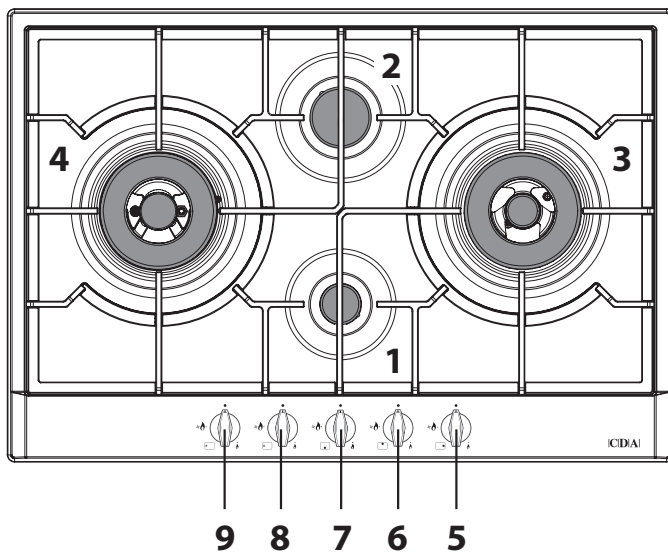

Fig. 7

ADVICE
for the
USERS

Features and Technical Data

Fig. 1



GAS BURNERS

- | | |
|---------------------|---------|
| 1. Auxiliary (A) | 1,00 kW |
| 2. Semirapid (SR) | 1,75 kW |
| 3. Triple-ring (TR) | 3,80 kW |
| 4. Dual (DB) (*) | 4,20 kW |

(*) IMPORTANT: The Dual burner is controlled by two separate knobs; one knob for the inner crown only and one knob for the outer crown only.

The inner and outer crown can be used together or separately.

After using the dual burner check both the control knobs are in the closed "●" position.

CONTROLS DESCRIPTION

5. Burner control knob (3)
6. Burner control knob (2)
7. Burner control knob (1)
8. Burner control knob (4), outer crown
9. Burner control knob (4), inner crown

NOTES:

- The electric ignition is incorporated in the knobs.
- The appliance has a safety valve system fitted, the flow of gas will be stopped if and when the flame should accidentally go out.

CAUTION:

If the burner is accidentally extinguished, turn the gas off at the control knob and wait at least 1 minute before attempting to re-light.

CAUTION:

Gas hobs produce heat and humidity in the environment in which they are installed. Ensure that the cooking area is well ventilated by opening the natural ventilation grilles or by installing an extractor hood connected to an outlet duct.

CAUTION:



If the hob is used for a prolonged time it may be necessary to provide further ventilation by opening a window or by increasing the suction power of the extractor hood (if fitted).

How To Use The Cooktop

GAS BURNERS

Gas flow to the burners is adjusted by turning the knobs (illustrated in fig. 2) which control the safety valves.

Turning the knob, so that the indicator line points to the symbols printed on the panel, achieves the following functions:

- symbol  closed valve
 - symbol  maximum opening or flow
 - symbol  minimum opening or flow
-
- The maximum opening position permits rapid boiling of liquids, whereas the minimum opening position allows slower warming of food or maintaining boiling conditions of liquids.
 - To reduce the gas flow to minimum rotate the knob further anti-clockwise to point the indicator towards the small flame symbol.
 - Other intermediate operating adjustments can be achieved by positioning the indicator between the maximum and minimum opening positions, and never between the maximum opening and closed positions.

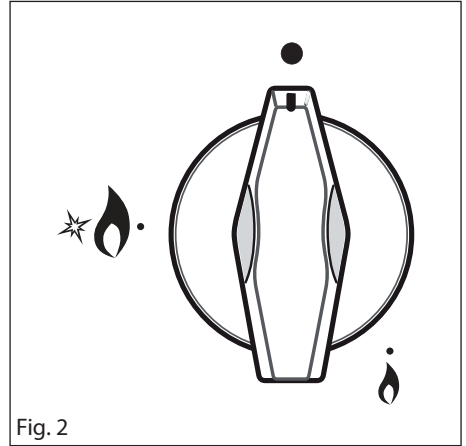

Fig. 2

NOTE:
The knob and symbols may vary.

Caution!
Do not cover the hob with aluminium foils.

N.B. When the cooktop is not being used, set the gas knobs to their closed positions and also close the cock valve on the gas bottle or the main gas supply line.

Caution!
The cooking hob becomes very hot during operation.
Keep children well out of reach.

LIGHTING THE BURNERS

To ignite the burner, the following instructions are to be followed:

1. Press in the corresponding knob and turn counter-clockwise (fig. 3) to the full flame position marked by the "★" symbol (fig. 2); hold the knob in until the flame has been lit.
In the case of a mains failure light the burner with a match or lighted taper.
2. Wait for a few seconds after the gas burner has been lit before letting go of the knob (valve activation delay).
3. Adjust the gas valve to the desired position.

If the burner flame should go out for some reason, the safety valve will automatically stop the gas flow.

To re-light the burner, return the knob to the closed "●" position, **wait for at least 1 minute** and then repeat the lighting procedure.

Note: If your local gas supply makes it difficult to light the burner with the knob set to maximum, set the knob to minimum and repeat the operation.

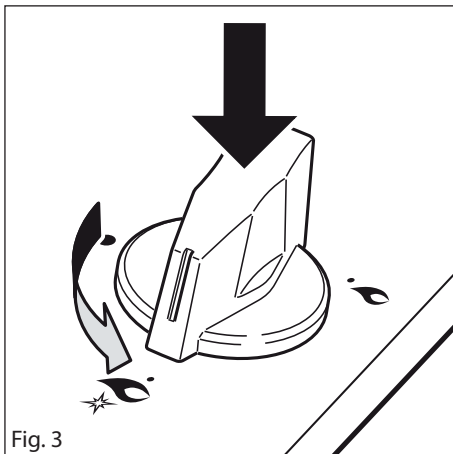

Fig. 3

DUAL BURNER - SOME MODELS ONLY

The Dual Burner is a very flexible burner which allows different regulations and optimal cooking.

It comprises one inner and one outer crown: **the inner and outer crown can be used together or separately.**

The Dual burner is **controlled by two separate knobs:**

- one knob for the inner crown only ("●" symbol identifying the control knob);
- one knob for the outer crown only ("○" symbol identifying the control knob).

The Dual burner can be used:

- as a small burner (flame produced only by the inner crown);
- as an ultra-rapid burner (flame produced only by the outer crown);
- as a high-power burner (all flames produced simultaneously by inner and outer crown).



IMPORTANT: After using the dual burner check both the control knobs are in the closed "●" position.

CHOICE OF THE BURNER

On the control panel, near every knob there is a diagram that indicates which burner is controlled by that knob.

The suitable burner must be chosen according to the diameter and the capacity used.

The burners and pans must be used in accordance with the following instructions:

DIAMETERS OF PANS WHICH MAY BE USED ON THE BURNERS

BURNERS	MINIMUM	MAXIMUM
Auxiliary	12 cm	14 cm
Semi-rapid	16 cm	24 cm
Triple-ring	26 cm	28 cm
Dual (inner crown only)	20 cm	24 cm
Dual (outer crown only)	26 cm	28 cm
Dual (inner+outer crown)	26 cm	28 cm
Wok	-	Max 36 cm

do not use pans with concave or convex bases

It is important that the diameter of the pot be suitable to the potentiality of the burner so as not to compromise the high output of the burners and therefore energy waste.

A small pot on a large burner does not give you a boiling point in a shorter amount of time since the capacity of heat absorption of a liquid mass depends on the volume and the surface of the pot. Too large a pot can cause damage to the burner and surrounding hob area.

CAUTION: Make sure the pans are central to the burner for maximum stability and greater efficiency.

Make sure the pans are not in contact with the control knobs, otherwise the flame could overheat the knobs and permanently damage them.

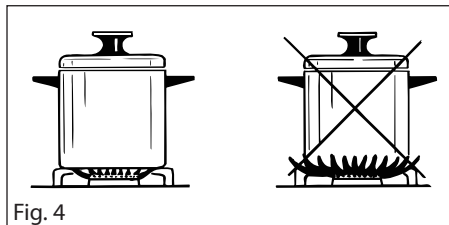

Fig. 4

WOK STAND (figs. 5a - 5b, 6a - 6b)

This special grille for woks should be placed over the pan-rest for the triple-ring or Dual burner.

Warning:

- Using woks without this special grille may cause the burner to malfunction.
- Do not use the grille for ordinary, flat-bottomed saucepans.

IMPORTANT:

The special grille for wok pans **MUST BE PLACED ONLY** over the pan-rest for the triple-ring or Dual burner .

TRIPLE-RING BURNER

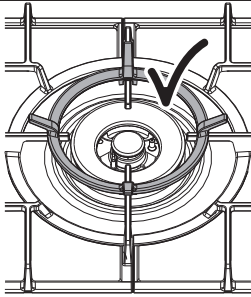

CORRECT

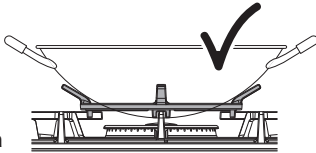
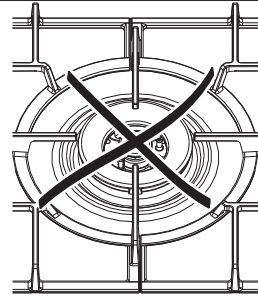

Fig. 5a



WRONG

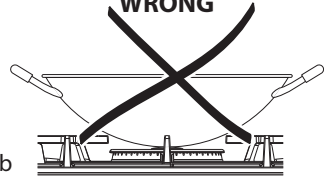
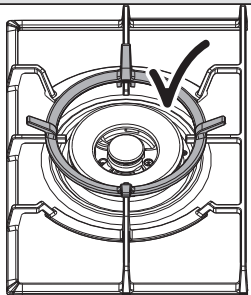

Fig. 5b

WITH DUAL BURNER



CORRECT

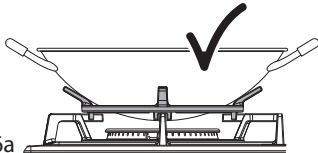
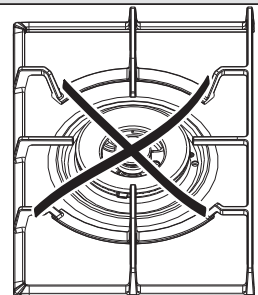

Fig. 6a



WRONG



Fig. 6b

Cleaning and Maintenance

GENERAL ADVICE

- **Before you begin cleaning, you must ensure that the appliance is switched off at the cooker switch.**
- The periodical lubrication of the gas taps must be done only by specialised personnel.
- If a tap becomes stiff, do not force; contact your local After Sales Service Centre.
- Be very careful that no water penetrates inside the appliance.
- It is advisable to clean when the appliance is cold and especially when cleaning the enamelled parts.
- Avoid leaving alkaline or acidic substances (lemon juice, vinegar, etc.) on the surfaces.
- **Avoid using cleaning products with a chlorine or acidic base.**
- **Important: The use of suitable protective clothing/gloves is recommended when handling or cleaning this appliance.**
- **Under no circumstances should any external covers be removed for servicing or maintenance except by suitable qualified personnel.**
- Clean surfaces with a damp cloth and use gentle, neutral cleaning products. Dry with a clean, dry cloth.
- **IMPORTANT:** Do not use any abrasive products (e.g. certain types of sponge) and/or aggressive products (e.g. caustic soda, products containing corrosive substances), which could cause irreparable surface damage.

WARNING:

When correctly installed, your product meets all safety requirements laid down for this type of product category.

However special care should be taken around the rear or the underneath of the appliance as these areas are not designed or intended to be touched and may contain sharp or rough edges, that may cause injury.

CLEANING

- **Stainless steel hob:** Spillage on the hob can usually be removed by a damp soapy cloth. More obstinate stains can be removed by using a proprietary stainless steel cleaning product that does not contain chlorine or acidic base.
- **Control panel:** Clean very carefully with water and neutral soap; the cloth used must be rinsed well and must be free of any cleaning chemicals to avoid damaging any screen print on the fascia.
- **Painted surfaces:** Clean very carefully with water and neutral soap; the cloth used must be rinsed well and must be free of any cleaning chemicals.
- **Pan stands & burner caps:** Clean with a sponge and soapy water or proprietary cream cleaner. Always dry thoroughly. **DO NOT PUT IN THE DISHWASHER.**
- **Burner bodies (aluminium alloy):** They should be cleaned with soapy water and a clean cloth. For stubborn stains a proprietary cream or stainless steel cleaner may be used; however to maintain a uniform finish we would recommend the whole area is cleaned. **NOTE:** Please ensure the slots/castellations are kept free of the any material/cleaner.
- **Gaskets fitted below control knobs:** Check they are well fitted and correctly in place.

Important: The manufacturer declines all liability for possible damage caused by the use of unsuitable products to clean the appliance.

Attention!

The appliance gets very hot, mainly around the cooking areas. It is very important that children are not left alone in the kitchen when you are cooking.

Do not use a steam cleaner because the moisture can get into the appliance thus make it unsafe.

GAS TAPS

- Do not let cleaning products come into contact with the valves.
- Periodic lubrication of the gas taps must be carried out by specialist personnel only.
- In the event of operating faults in the gas taps, call the Service Department.

BURNERS

These parts must be cleaned using a sponge and soapy water or other suitable non-abrasive products. Dry with a soft cloth.

Warning! Not dishwasher safe.

After cleaning, the burners and their flame spreaders must be well dried and correctly replaced. It is very important to check that the burner flame spreader and the cap have been correctly positioned. Failure to do so can cause serious problems.

Check that the electrode/s “**S**” (figs. 7, 9, 10) next to each burner is/are always clean to ensure trouble-free sparking.

Check that the probe/s “**T**” (figs. 7, 9, 10) next to each burner is/are always clean to ensure correct operation of the safety valves.

Both the probe and ignition plug must be very carefully cleaned.

Note: To avoid damage to the electric ignition do not use it when the burners are not in place.

Note: Continuous use may cause a change in the glaze around the burners and grids, corresponding to the areas exposed to the heat. This is a natural phenomenon and does not prevent the parts from working properly.

CORRECT REPLACEMENT OF THE AUXILIARY and SEMI-RAPID BURNER

It is very important to check that the burner flame distributor “**F**” and the cap “**C**” have been correctly positioned (see figs. 7, 8) - failure to do so can cause serious problems.

CORRECT REPLACEMENT OF THE TRIPLE-RING AND DUAL BURNER

The burner must be correctly positioned; failure to do so can cause serious problems.

Fit the flame spreader to the housing as shown by the arrows (see figs. 9, 10).

The burner correctly positioned must not rotate (fig. 11).

Then position the cap “**A**” and the ring “**B**” (figs. 11, 12).

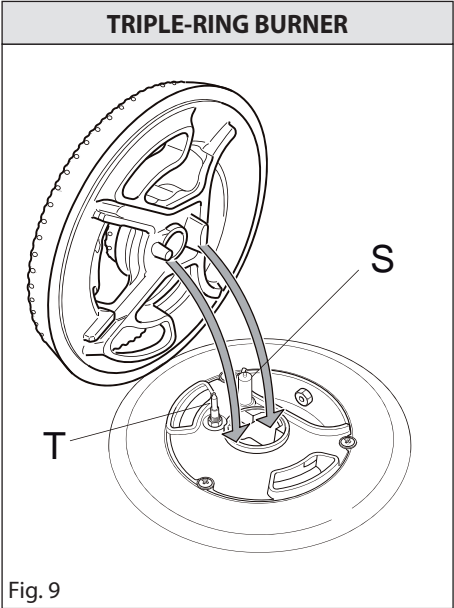
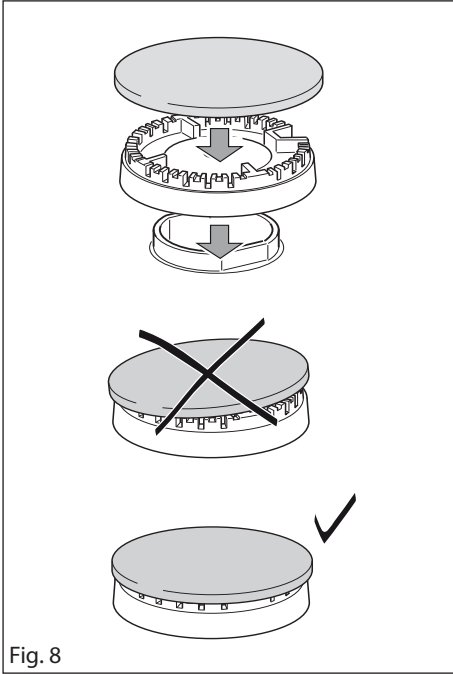
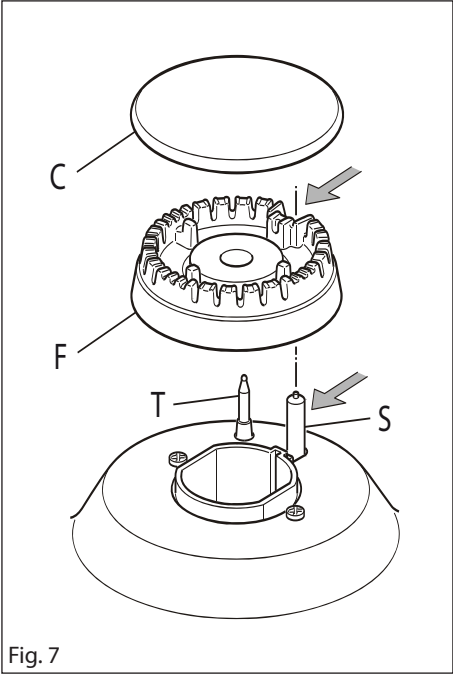

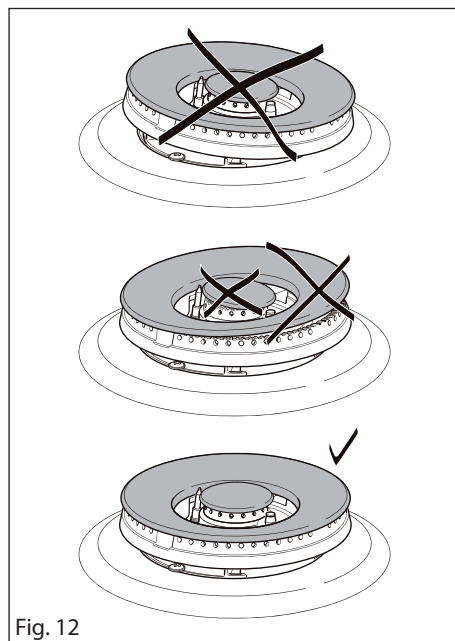
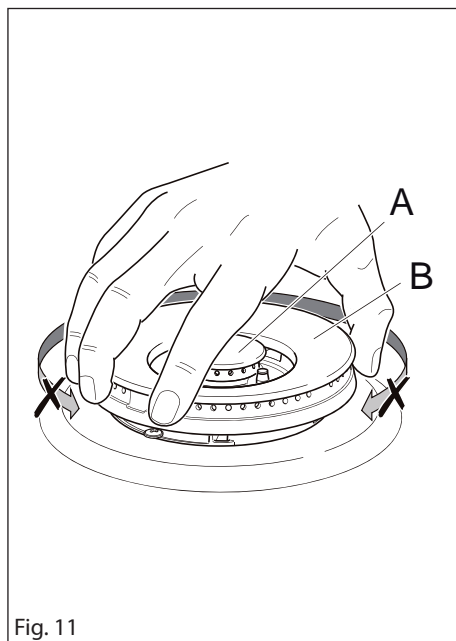
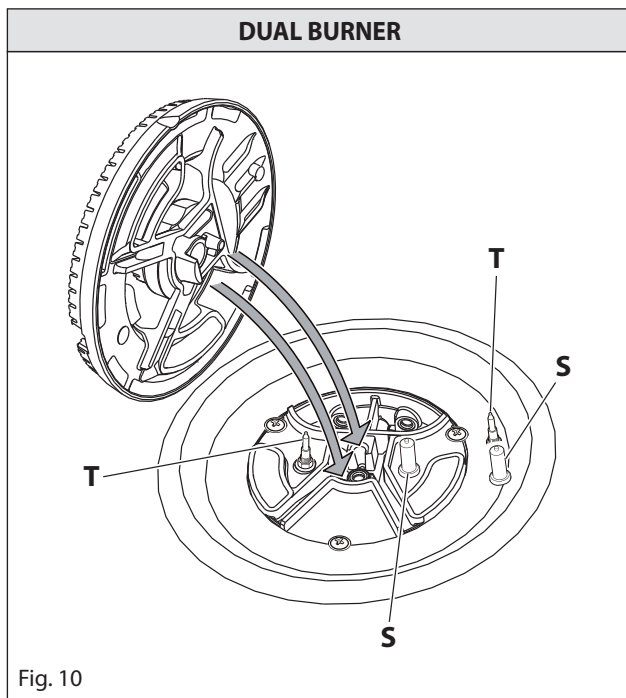

PAN SUPPORTS

These parts can be removed and cleaned with appropriate products.

After cleaning, they must be well dried and correctly replaced.

It is very important to check that the pan supports have been correctly positioned. Failure to do so can cause serious problems.

The prongs of the pan supports must always be centred with the burners (fig. 13).

The raised portion of the pan supports shall NOT face the sides of the cooktop (fig. 14).

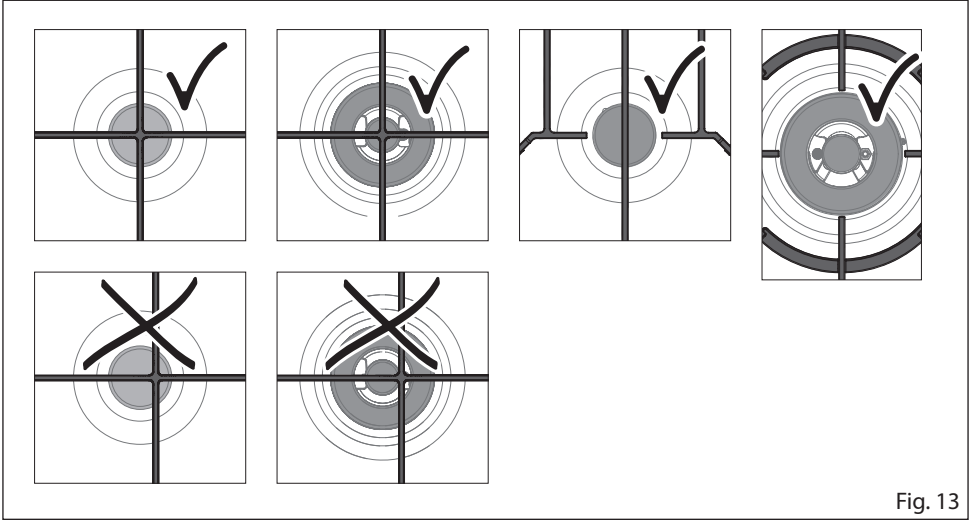

Fig. 13

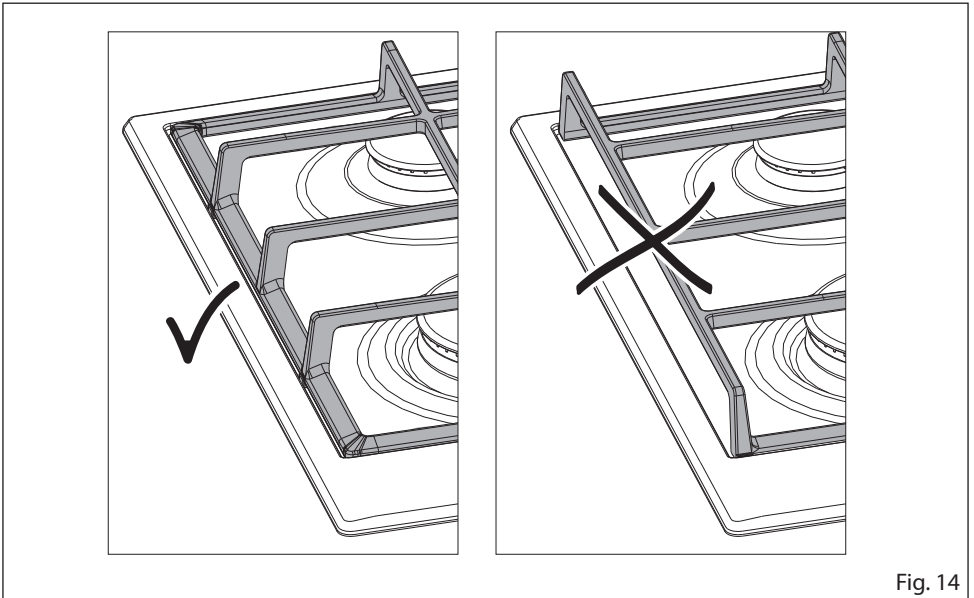

Fig. 14

Appliance Servicing

CDA provide a quality and effective after-sales service to cover all your servicing needs.

Please attach your receipt to this page for safekeeping.

Please help us to help you by having the following information available when booking a service-call:

1. Model type, make and model – see the product data plate.
2. Evidence of installation / purchase date.
3. Retailer where appliance was purchased.
4. Clear and concise details of the fault.
5. Full address including postcode and any contact phone numbers.

Contact Telephone Numbers

CDA Customer Care Department

- Telephone: 01949 862012
- Fax: 01949 862003
- Email: customer.care@cda.eu



Cod. 1106172 - β1

Please contact our Customer Care Department for Service on the details below

Customer Care Department
The CDA Group Ltd. • Harby Road • Langar • Nottinghamshire • NG13 9HY
T : 01949 862 012 F : 01949 862 003 E : customer.care@cda.eu

