

FF881

Freestanding full height frost free freezer

Use and maintenance

Contents:

3	Important information
4	Before first use
5	Important safety notes
7	Freezer use
9	Energy saving tips
10	Food storage suggestions
13	Freezer layout and storage
14	Control panel layout
15	Setting the temperature
15	Super freeze mode
16	Stand-by mode
16	Temperature setting warnings
17	Important installation instruction note
18	Fridge storage and accessories
19	Maintenance, care and cleaning
21	Troubleshooting
25	Installation and ventilation
25	Appliance dimensions
28	Electrical information

Important

CDA cannot be held responsible for injuries or losses caused by incorrect use or installation of this product. Please note that CDA reserve the right to invalidate the guarantee supplied with this product following incorrect installation or misuse of the appliance.

Under no circumstances should any external covers be removed for servicing or maintenance except by suitably qualified personnel.

Do not use the appliance if the plug, the mains cord or the appliance itself is damaged. If the mains cord is damaged, you must have it replaced by the manufacturer, or an authorised service centre or similarly qualified person in order to avoid a hazard.

Appliance information:

Please enter the details on the appliance rating plate below for reference, to assist CDA Customer Care in the event of a fault with your appliance and to register your appliance for guarantee purposes.

Appliance Model	
Serial Number	

EU Declarations of Conformity:

This appliance meets the requirements of all applicable EU directives with the corresponding harmonised standards which provide for CE marking.



WARNING: Risk of fire/flammable materials

IMPORTANT INFORMATION FOR CORRECT DISPOSAL OF THE PRODUCT IN ACCORDANCE WITH WEEE DIRECTIVE 2012/19/EU.

At the end of its working life, the product must not be disposed of as urban waste. It must be taken to a special local authority differentiated waste collection centre or to a dealer providing this service.

Disposing of a household appliance separately avoids possible negative consequences for the environment and health deriving from inappropriate disposal and enables the constituent materials to be recovered to obtain significant savings in energy and resources. As a reminder of the need to dispose of household appliances separately, the product is marked with a crossed-out wheeled dustbin .

Before first use of the freezer

You must allow the freezer to settle for at least five hours prior to switching the power on. The freezer may have an odour to it at first use. This will disappear as the appliance cools.

It is recommended that you clean the interior of the appliance prior to first use, using a solution of bicarbonate of soda and warm water then thoroughly dry the interior.

This appliance has been designed with ease of use in mind but please read the following instructions carefully to ensure you familiarise yourself with the appliance and its operation. This will help you to get the best results and also help to prevent you from being charged for unnecessary service calls.

- This refrigeration appliance is not intended for use as a built in appliance.
- When you first switch on the appliance, you should ideally run it without any contents for the first 24 hours and not open the appliance doors. If you need to use it straight away, try not to put a large quantity of food inside.
- The appliance will work continuously until it comes down to the correct temperature.
- This appliance features a five minute delay function which, after power has been cut and restored or the appliance turned off and on again, allows five minutes to pass before switching the cooling system on again. This is to prevent unnecessary damage to the compressor.
- The climate class for this appliance is T/SN. This means ambient temperatures should not fall below 10°C or exceed 38°C.
- Two-star frozen-food compartments are suitable for storing pre-frozen food, storing or making ice cream and making ice cubes.
- One-, two- and three-star compartments are not suitable for the freezing of fresh food.

Important safety notes

This appliance is not intended for use by persons (including children) with reduced physical, sensory or mental capabilities, or lack of experience and knowledge, unless they have been given supervision or instruction concerning use of the appliance by a person responsible for their safety.

- Children must not play with the appliance.

-
- Cleaning and user maintenance must not be made by children without supervision.
 - If the appliance is switched off, you should allow five minutes before switching it on again to prevent unnecessary damage to the compressor.

WARNING - Keep ventilation openings clear of obstruction.

WARNING - Do not use mechanical devices or other means to accelerate the defrosting process.

WARNING - Do not use electrical appliances inside the food storage compartments of the appliance.

WARNING - Do not damage the refrigerant circuit.

WARNING - Do not store explosive substances such as aerosol cans, with a flammable propellant, within this appliance.

- Children should be supervised to ensure that they do not play with the appliance.
- This appliance is not intended for use at altitudes exceeding 2000m.
- This appliance is a household refrigerator and is intended to be used in domestic environments and similar applications such as staff kitchen areas, farm houses and bed and breakfast type environments. It should not be used in commercial environments.
- If your appliance uses R600a as a refrigerant (this information will be provided on the rating plate) you must take care during

transportation and installation to prevent the cooling system elements from being damaged. R600a is an environmentally friendly and natural gas, but is explosive. In the event of a leak due to damage to the cooling system, move your freezer away from open flames or heat sources and ventilate the room in which the appliance is located for 5 minutes.

Freezer use

For normal operating conditions, set the temperature of the freezer compartment to -18 or -20 °C.

- The freezer is used for storing frozen food, freezing fresh food, and making ice cubes.
- Food in liquid form should be frozen in plastic cups and other food should be frozen in plastic folios or bags. For freezing fresh food; wrap and seal fresh food properly, that is the packaging should be air tight and shouldn't leak. Special freezer bags, aluminum foil polythene bags and plastic containers are ideal.
- Do not store fresh food next to frozen food as it can thaw the frozen food.
- Before freezing fresh food, divide it into portions that can be consumed in one sitting.
- Consume thawed frozen food within a short period of time after defrosting.
- Always follow the manufacturer's instructions on food packaging when storing frozen food. If no information is provided food, should not be stored for more than 3 months from the date of purchase.
- When purchasing frozen food, make sure that it has been stored under appropriate conditions and that the packaging is not damaged.

- Frozen food should be transported in appropriate containers and placed in the freezer as soon as possible.
- Do not purchase frozen food if the packaging shows signs of humidity and abnormal swelling. It is probable that it has been stored at an unsuitable temperature and that the contents have deteriorated.
- The storage life of frozen food depends on the room temperature, the thermostat setting, how often the door is opened, the type of food, and the length of time required to transport the product from the shop to your home. Always follow the instructions printed on the packaging and never exceed the maximum storage life indicated.
- If the freezer door has been left open for a long time or not closed properly, frost will form and can prevent efficient air circulation. To resolve this, unplug the freezer and wait for it to defrost. Clean the freezer once it has fully defrosted.
- The freezer volume stated on the label is the volume without baskets, covers, and so on.
- Do not refreeze thawed food. It may pose a danger to your health and cause problems such as food poisoning.

NOTE: If you attempt to open the freezer door immediately after closing it, you will find that it will not open easily. This is normal. Once equilibrium has been reached, the door will open easily.

If you would use maximum freezing capacity of your freezer:

- While freezing fresh foods, the maximum amount of fresh food (in kg) that can be frozen in 24 hours is indicated on the appliance label.
- For optimum appliance performance to reach maximum freezing

capacity, activate Super Freeze (SF) mode 24 hours before placing fresh food into the freezer.

- After placing fresh food into the freezer, 24 hours is generally sufficient for freezing. "Super Freeze" mode will be deactivated automatically in 2-3 days to save energy.

If you would freeze a small amount (upto 3 kg) in your freezer:

- Place your food without touching already frozen food and activate "Fast Freezing" mode. You can put your food next to other frozen food after it is completely frozen (after minimum 24 hours).
- Do not re-freeze frozen food after it has thawed. This may cause health issues, such as food poisoning.
- Allow hot food to completely cool down before placing it in the freezer.
- When buying frozen food ensure that these have been frozen at suitable temperatures and that the packing is intact.
- Use the fast freezing shelf to freeze home cooking (and any other food which needs to be frozen quickly) more quickly because of the freezing shelf's greater freezing power. Fast freezing shelf is the bottom drawer of the freezer compartment.
- To use the maximum capacity of the freezer compartment, use the glass shelves for the upper and middle section, and use the lower basket for the bottom section.

The following tables are a quick guide to show you the most efficient way to store the major food groups in your freezer compartment.

Meat and fish	Preparation	Maximum storage time (months)
Steak	Wrap in foil	6-8
Lamb meat	Wrap in foil	6-8
Veal roast	Wrap in foil	6-8
Veal cubes	In small pieces	6-8
Lamb cubes	In pieces	4-8
Minced meat	In packaging without using spices	1-3
Giblets (pieces)	In pieces	1-3
Bologna sausage/salami	Should be kept packaged even if it has a membrane	1-3
Chicken and turkey	Wrap in foil	4-6
Goose and duck	Wrap in foil	4-6
Deer, rabbit, wild boar	In 2.5 kg portions or as fillets	6-8
Freshwater fish (Salmon, Carp, Crane, Catfish)	After cleaning the bowels and scales of the fish, wash and dry it. If necessary, remove the tail and head	2
Lean fish (Bass, Turbot, Flounder)		4
Fatty fishes (Tuna, Mackerel, Bluefish, Anchovy)		2-4
Shellfish	Clean and in a bag	4-6
Caviar	In its packaging, or in an aluminium or plastic container	2-3
Snails	In salty water, or in an aluminium or plastic container	3
NOTE: Thawed frozen meat should be cooked as fresh meat. If the meat is not cooked after defrosting, it must not be re-frozen.		

Vegetables and fruits	Preparation	Maximum storage time (months)
String beans and beans	Wash, cut into small pieces and boil in water	10-13
Beans	Hull, wash and boil in water	12
Cabbage	Clean and boil in water	6-8
Carrot	Clean, cut into slices and boil in water	12
Pepper	Cut the stem, cut into two pieces, remove the core and boil in water	8-10
Spinach	Wash and boil in water	6-9
Cauliflower	Remove the leaves, cut the heart into pieces and leave it in water with a little lemon juice for a while	10-12
Eggplant	Cut into pieces of 2cm after washing	10-12
Corn	Clean and pack with its stem or as sweet corn	12
Apple and pear	Peel and slice	8-10
Apricot and peach	Cut into two pieces and remove the stone	4-6
Strawberry and blackberry	Wash and hull	8-12
Cooked fruits	Add 10 % of sugar to the container	12
Plum, cherry, sourberry	Wash and hull the stems	8-12

	Maximum storage time (months)	Thawing time at room temperature (hours)	Thawing time in oven (minutes)
Bread	4-6	2-3	4-5 (220-225 °C)
Biscuits	3-6	1-1.5	5-8 (190-200 °C)
Party	1-3	2-3	5-10 (200-225 °C)
Pie	1-1.5	3-4	5-8 (190-200 °C)
Phyllo dough	2-3	1-1.5	5-8 (190-200 °C)
Pizza	2-3	2-4	15-20 (200 °C)

Dairy products	Preparation	Maximum storage time (months)	Storage conditions
Packet (Homogenized) Milk	In its own packet	2-3	Pure Milk – in its own packet
Cheese - excluding white cheese	In slices	6-8	Original packaging may be used for short-term storage. Keep wrapped in foil for longer periods.
Butter, margarine	In its packaging	6	

Freezer layout and storage

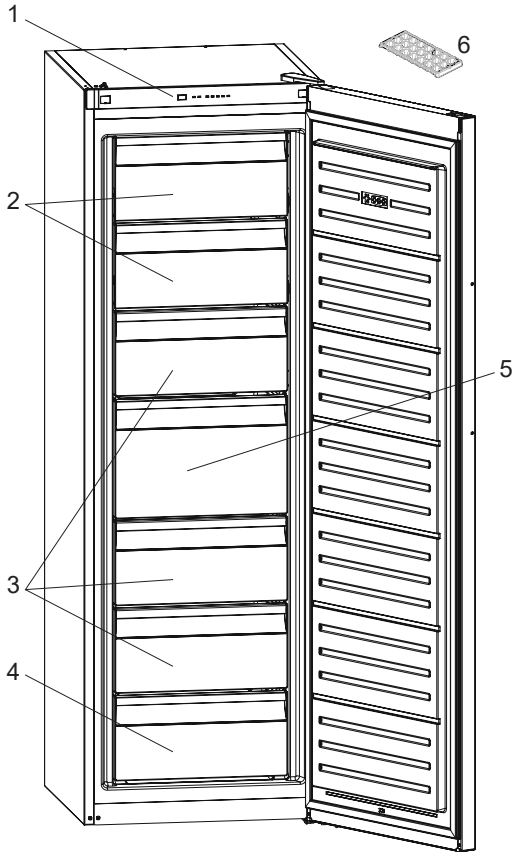

- | | | | |
|----|-----------------|----|-----------------------|
| 1. | Control panel | 4. | Freezer bottom drawer |
| 2. | Freezer flaps | 5. | Freezer big drawer |
| 3. | Freezer drawers | 6. | Ice tray |

No-frost technology

No-frost freezers differ from other static freezers in the way they operate. In normal freezers, the humidity entering the freezer due to opening the door and the humidity inherent in the food causes freezing in the freezer compartment. To defrost the frost and ice in the freezer compartment, you are periodically required to turn off the freezer, place the food that needs to be kept frozen in a separately cooled container and remove the ice gathered in the freezer compartment. The situation is completely different in no-frost freezers. Dry and cold air is blown into the freezer compartment homogeneously and evenly from several points via a blower fan. Cold air dispersed homogeneously and evenly between the shelves cools all of your food equally and uniformly, thus preventing humidity and freezing. Therefore your no-frost freezer allows you ease of use, in addition to its huge capacity and stylish appearance.

Control panel and usage

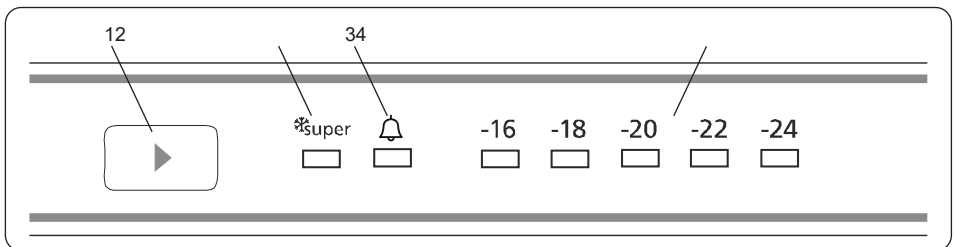

1. Freezer temperature set button
2. Super freeze symbol (Super freeze LED)
3. Alarm symbol (Alarm LED)
4. Freezer adjusted temperature indicator

Setting the temperature

The default temperature for the freezer at first switch on should be -18°C. To adjust the temperature:

- Press the freezer setting button once to decrease the temperature.
- Every time you press the button, the temperature will increase. (-16 °C, -18 °C, -20 °C, Super freezing)
- Press the freezer setting button until super freeze symbol is displayed on your freezer.
- Once these settings are displayed and no button is pressed within 3 seconds, the super freeze indicator will blink.
- If you keep pressing the freezer setting button, it will restart from last value.

Super freeze mode

Super freeze mode brings the freezer temperature down quickly. We recommend using this function when introducing large amounts of fresh food at once, such as your weekly shop.

To use the super cool mode:

- Press temperature set button until super freeze light comes on.
- Super freeze led will light during this mode.
- For optimal appliance performance in maximum freeze capacity, set the appliance to active super freeze mode 24 hours before you put fresh food into the freezer.

To cancel the super freeze mode:

- Pressing the temperature set button will cancel the mode and the setting will be restored from -16.

Note: The super freeze mode will cancel automatically after 54 hours depending on the environmental temperature or when the freezer sensor reaches a sufficiently low temperature..

Stand-by mode

Stand-by mode will disable all components, if you the set button is pressed whilst in stand-by mode, all LEDs will blink three times to indicate that stand-by mode is active.

To activate stand-by mode:

- Set “-16” set value and push set button until all leds are blink three times.

To cancel stand-by mode:

- Push and hold the set button until the display returns to normal working. After the mode is deactivated, the “Alarm LED” may light on the display because the product may be hot. The “Alarm LED” will turn off when the product reaches normal temperature.

Temperature setting warnings

- Your appliance is designed to operate in the ambient temperature ranges stated in the standards, according to the climate class stated in the information label. It is not recommended that your freezer is operated in the environments which are outside of the stated temperature ranges. This will reduce the cooling efficiency of the appliance.
- Temperature adjustments should be made according to the frequency of door openings, the quantity of food kept inside the

appliance and the ambient temperature in the location of your appliance.

- When the appliance is first switched on, allow it to run for 24 hours in order to reach operating temperature. During this time, do not open the door and do not keep a large quantity of food inside.
- A 5 minute delay function is applied to prevent damage to the compressor of your appliance when connecting or disconnecting to mains, or when an energy breakdown occurs. Your appliance will begin to operate normally after 5 minutes.

Important installation instructions

This appliance is designed to work in difficult climate conditions and is powered with 'Freezer Shield' technology which ensures that the frozen food in the freezer will not defrost even if the ambient temperature falls as low as -15 °C.

This means the appliance may be installed in an unheated room without having to worry about frozen food in the freezer being spoiled. When the ambient temperature returns to normal, you may continue using the appliance as usual.

Freezer storage and accessories

Ice tray

Fill the ice tray with water and place in the freezer compartment. After the water has completely frozen, you can twist the tray as shown below to remove the ice cubes.

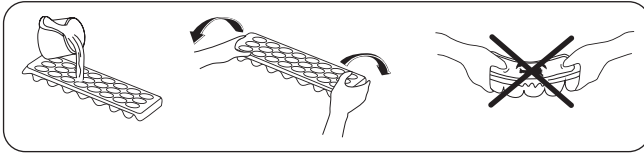

Maintenance, care and cleaning

Always disconnect the appliance from the power before ANY cleaning or maintenance.

- Leave spaces between food items wherever possible to allow air to flow between them. Do not allow food items or containers to touch the rear or side walls of the appliance, nor obstruct the fan.
- Avoid contact of oily or acidic foods with the rear and side walls. Oils and acids can damage the liner material. If any such foods come into contact with the walls, clean the spot with warm water and bicarbonate of soda.
- The refrigerator section should be cleaned using a solution of bicarbonate of soda and lukewarm water. Make sure that no water enters the lamp housing or other electrical components.
- Do not use abrasive products or detergents.
- Clean the shelves and balconies separately by hand, using soap and water. Do not put them in the dishwasher.
- Keep the door seal clean to avoid damage to them and to help to ensure that they continue to function correctly.
- Once cleaning is complete, then reconnect the power.
- If the appliance is not used for prolonged periods of time, unplug and clean it. The doors should be left slightly open to prevent the formation of mildew or odours.
- Where possible, clean the condenser (black grille on the back of the appliance) with a soft bristle brush at least twice a year.

Defrosting

- Your appliance performs automatic defrosting. The water formed as a result of defrosting passes through the water collection spout, flows into the water tray behind your appliance and evaporates there.
- Make sure you have disconnected the plug of your appliance before cleaning the water tray.
- Remove the water tray from its position by removing the screws (if it has screws). Clean it with soapy water at specific time intervals. This will prevent odours from forming.

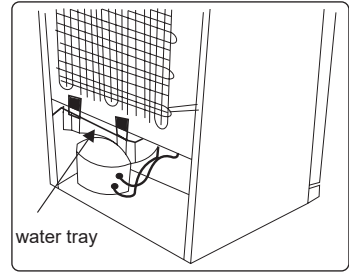

Changing the light bulb

To replace any of the LEDs, please contact the CDA Customer Care department.

- If the appliance is equipped with an LED lamp, this light source is an energy efficiency class <E>.
- If the appliance is equipped with LED Strip(s) or LED card(s), this light source is an energy efficiency class <F>.

Note: The numbers and location of the LED strips may change according to the model.

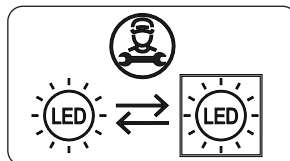

Troubleshooting

If you have any problems with your appliance, you should check the troubleshooting prior to calling CDA Customer Care, to prevent unnecessary service calls and potential cost. Contact details for CDA Customer Care are on the rear cover of this manual.

Your appliance will warn you if the temperature is not within the proper or if a problem occurs with the appliance. In the case of a problem within the appliance, the alarm led will show a red light.

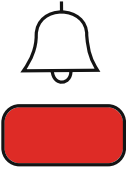
Alarm indicator LED is turning on	Meaning	Why	What to do
	"Failure" Warning	There is/are some part(s) out of order or there is a failure in the cooling process. The product is plugged in for the first time or a long-time power interruption for 1 hour.	Check if the door is open, then check if the appliance is working after 1 hour. If the door is not open and the appliance has not worked for 1 hour, contact CDA customer care department for assistance as soon as possible.

If you are experiencing a problem with your appliance, please check the following troubleshooting tables before contacting the CDA customer care department.

CDA Customer Care

Phone: 01949 862 012

Email: customer.care@cda.co.uk

Issue	Check / Explanation
Appliance is not operating	<ul style="list-style-type: none"> • There is power • The plug is correctly placed in the socket • The plug fuse or the mains fuse has blown • The socket is defective. To check this, plug another working appliance into the same socket
Appliance is performing poorly	<ul style="list-style-type: none"> • The appliance is overloaded • The appliance door is closed properly • There is any dust on the condenser • There is enough space near the rear and side walls
Appliance is operating noisily (Cracking noise occurs)	<ul style="list-style-type: none"> • This occurs during automatic defrosting or when the appliance is cooled or warmed (due to expansion of appliance material) and is normal
Appliance is operating noisily (Short cracking noise occurs)	<ul style="list-style-type: none"> • This occurs the thermostat switches the compressor on/off
Appliance is operating noisily (Motor noise)	<ul style="list-style-type: none"> • This indicates the compressor is operating normally • The compressor may cause more noise for a short time when it is first activated and is normal
Appliance is operating noisily (Bubbling noise/splash)	<ul style="list-style-type: none"> • This occurs due to the flow of the refrigerant in the tubes of the system
Appliance is operating noisily (Water flowing noise)	<ul style="list-style-type: none"> • This occurs due to water flowing to the evaporation container and this noise is normal during defrosting
Appliance is operating noisily (Water flowing noise)	<ul style="list-style-type: none"> • This occurs in some models during normal operation of the system due to the circulation of air
The edges of the appliance in contact with the door joint are warm	<ul style="list-style-type: none"> • This may occur during summer (warm seasons) especially, as the surfaces in contact with the door joint may become warmer during the operation of the compressor, this is normal

Issue	Check / Explanation
There is a build-up of humidity inside the appliance	<ul style="list-style-type: none"> • All food is packed properly, containers must be dry before being placed in the appliance • The appliance door is opened frequently - the humidity of the room enters the appliance when the doors are opened and increases faster when the doors are opened more frequently, especially if the humidity of the room is high
The door does not open or close properly	<ul style="list-style-type: none"> • There is food or packaging preventing the door from closing • The door joints are broken or torn • Your appliance is on a level surface • The compressor can run loudly or the noise of the compressor/refrigerator may increase in some models during operating • in some conditions such that the product is plugged in for the first time, depending on change in the ambient temperature or change of usage - this is normal; when the refrigerator reaches the required temperature, the noise decreases automatically

Important! All repairs must be performed by qualified service technicians. The use of engineers not approved by CDA may invalidate any warranty provided.

In the event of your appliance requiring technical assistance and/or spare parts, please contact CDA Customer Care. In this case it is necessary to state all the appliance data on the rating plate, such as model, serial number etc. If the problem is not solved, disconnect the power supply and report the fault.

For more information about the warranty of your product, including terms and conditions, please visit www.cda.co.uk/warranty

Troubleshooting recommendations

- If the appliance is switched off or unplugged, wait at least 5 minutes before plugging the appliance in or restarting it in order to prevent damage to the compressor.
- If you will not use your appliance for a long time (e.g. in summer holidays) unplug it. Clean your appliance according to chapter cleaning and leave the door open to prevent humidity and smell.
- If a problem persists after you have followed all the above instructions, please contact the CDA customer care department.
- The appliance you have purchased is designed for domestic use only. It is not suitable for commercial or common use. If the consumer uses the appliance in a way that does not comply with this, we emphasise that the manufacturer and the retailer will not be responsible for any repair and failure within the guarantee period.

Installation and ventilation

When installing this product we recommend you seek the help of another individual. This product may have some sharp edges. Please take care and wear adequate PPE when handling.

This appliance must never be installed close to heat sources such as heating elements, radiators, ovens and cookers nor installed in damp places or direct sunlight.

Product dimensions

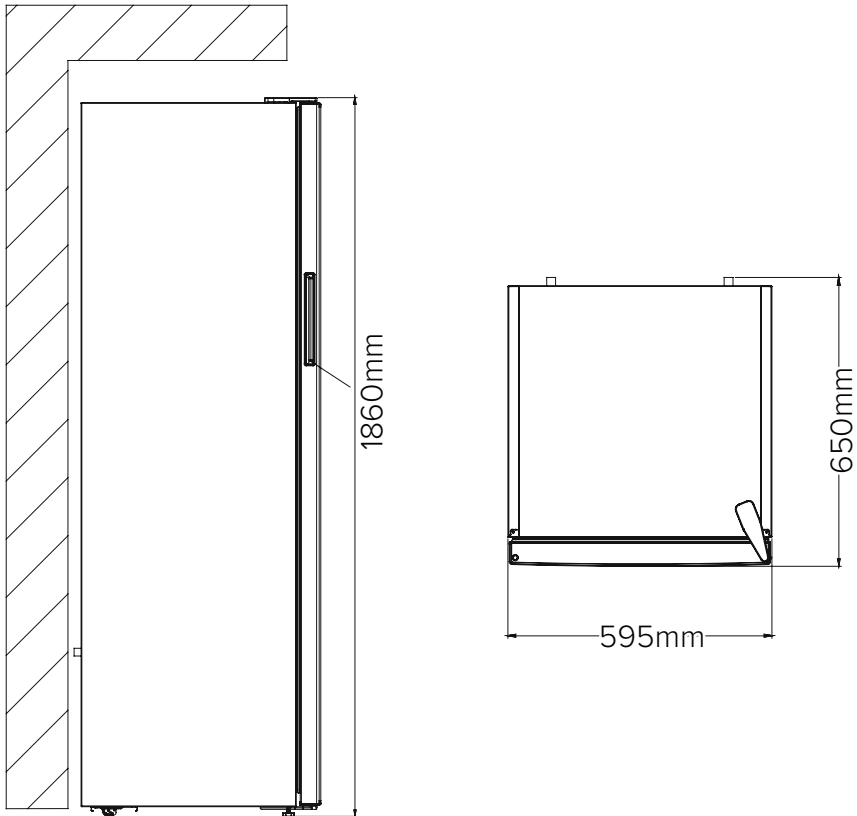

Before using your freezer for the first time, please pay attention to the following points:

The operating voltage for your freezer is 220-240 V at 50Hz.

- The plug must be accessible after installation.
- Your freezer may have an odour when it is operated for the first time. This is normal and the odour will fade when your freezer starts to cool.
- Before connecting your freezer, ensure that the information on the data plate (voltage and connected load) matches that of the mains electricity supply. If in doubt, consult a qualified electrician.
- Insert the plug into a socket with an efficient ground connection. If the socket has no ground contact or the plug does not match, we recommend you consult a qualified electrician for assistance.
- The appliance must be connected with a properly installed fused socket.
- The power supply (AC) and voltage at the operating point must match with the details on the name plate of the appliance (the name plate is located on the inside left of the appliance).
- We do not accept responsibility for any damages that occur due to ungrounded usage.
- Place your freezer where it will not be exposed to direct sunlight.
- Your freezer must never be used outdoors or exposed to rain.
- Your appliance must be at least 50 cm away from stoves, gas ovens and heater cores, and at least 5 cm away from electrical ovens.
- If your freezer is placed next to a deep freezer, there must be at least 2 cm between them to prevent humidity forming on the outer surface.

- Do not cover the body or top of freezer with lace. This will affect the performance of your freezer.
- Clearance of at least 150 mm is required at the top of your appliance. Do not place anything on top of your appliance.
- Do not place heavy items on the appliance.
- Clean the appliance thoroughly before use (see Cleaning and Maintenance).
- Before using your freezer, wipe all parts with a solution of warm water and a teaspoon of sodium bicarbonate. Then, rinse with clean water and dry. Return all parts to the freezer after cleaning.
- Use the adjustable front legs to make sure your appliance is level and stable. You can adjust the legs by turning them in either direction. This must be done before placing food in the appliance.
- Install the plastic distance guide(s) on the condenser (black vanes at the rear of the appliance) by turning it 90° (as shown in the figure) to prevent the condenser from touching the wall.
- The distance between the appliance and back wall must be a maximum of 75 mm.

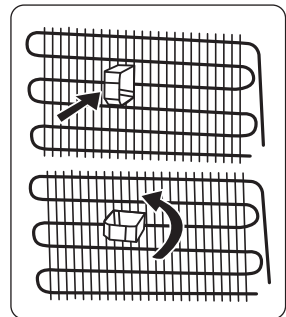

Electrical information

Warning! This appliance must be earthed. The mains lead of this appliance has been fitted with a specially earthed plug.

Important: Do not use the appliance without the fuse cover in position. Should the fuse need to be replaced, it must be replaced with a 13A fuse, ASTA approved to BS1362.

The plug must be used with a specially earthed socket of 13 amperes. If there is no such socket in your house, please have one installed by an authorised electrician. If in doubt regarding the electrical connection of this appliance, consult a qualified electrician. Do not shorten the supply cable, the appliance may require removal for servicing.

N.B. Ensure that the plug socket is situated in an easily accessible place. If the power supply cable or plug is damaged, it must be replaced by a CDA authorised agent. If the plug socket does not match the refrigerator plug, it must be replaced by the manufacturer or an authorised service agent in order to avoid a hazard.

WARNING: When positioning the appliance, ensure the supply cord is not trapped or damaged.

WARNING: Do not locate multiple portable socket outlets or portable power supplies at the rear of the appliance.

WARNING: Do not use plug adapters with this appliance.

The mains lead of this appliance has been fitted with a BS 1363A 13A fused plug. To change a fuse in this type of plug, follow the steps below:

1. Remove the fuse cover and fuse.
2. Fit replacement 13A fuse, ASTA approved to BS 1362 type, into the fuse cover.
3. Replace fuse cover.

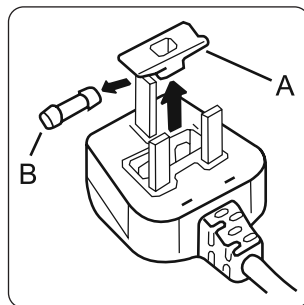

During usage

- Do not connect your freezer to the mains electricity supply using an extension lead or a plug adapter.
- Do not use damaged, torn or old plugs.
- Do not pull, bend or damage the cord.
- This appliance is designed for use by adults. Do not allow children to play with the appliance or hang off the door.
- Never touch the power cord/plug with wet hands. This may cause a short circuit or electric shock.
- Do not place glass bottles or cans in your freezer as they will burst when the contents freeze.
- Do not place explosive or flammable material in your freezer.
- When removing ice from the ice-making compartment, do not touch it. Ice may cause frost burns and/or cuts.
- Do not touch frozen goods with wet hands. Do not eat ice-cream or ice cubes immediately after they are removed from the ice-making compartment.
- Do not re-freeze thawed frozen food. This may cause health issues such as food poisoning.

When the door of the freezer is closed, a vacuum seal will form. Wait for 1 minute before reopening it. This application is optional for easy opening of the door. With this application, a little condensation may occur around this area and you may remove it.

Notes

Notes



For service or queries relating to your product please contact:

The Customer Care Department on **01949 862 012** or email **customer.care@cda.co.uk**

For more information please contact:

The Sales Department on **01949 862 010** or email **sales@cda.co.uk**

Customer Care Department. The CDA Group Ltd, Harby Road, Langar, Nottinghamshire, NG13 9HY
T: 01949 862 012 **F:** 01949 862 003 **E:** customer.care@cda.co.uk