



## FW422 Integrated in-column larder fridge

### Features

- Interior light
- 1 egg tray
- 2 salad crisper drawers
- In-door balconies: 3
- Glass shelves: 4
- Reversible doors
- Control system: Mechanical
- Left/ Right hinged door: Left

### Technical specification

- Noise efficiency class: C
- Fixed hinges
- Total useable capacity: 134L net
- Noise level: 38dBA
- Climate class: N-T
- Fridge net capacity: 134
- Number of compressors: 1
- Power supply: 13A
- Rated power: 95W
- Refrigerant quantity: 26g
- Refrigerant type: R600a
- UK plug
- Voltage/frequency: 220-240/50

### Energy

- Energy consumption per annum: 116kW.h
- Energy rating: F

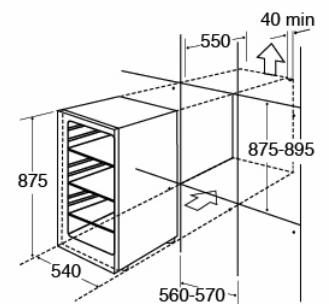

➔ = airflow